

# SWEDISH AMERICAN HOSPITAL HEART AND VASCULAR CENTER

## FINAL REPORT



PHILIP FREDERICK  
AE SENIOR THESIS  
PENNSYLVANIA STATE UNIVERSITY

ADVISOR: DR. ANDRES LEPAGE





## The Swedish American Hospital - Heart and Vascular Center

### Project Team

Building Owner : Swedish American Hospital  
Architect : Perkins and Will Architects  
Structural Engineer : Simpson Gumpertz and Heger  
MEP Engineer : KJWW Engineering Consultants  
Civil Engineer : ARC Design Resources, INC  
General Contractor : Turner Construction  
Delivery Method : Guaranteed Max Price (GMP)

### Building Statistics

Location : 1400 Charles St  
Rockford, IL 61108  
Construction Dates : December 2004  
February 2006  
Size : 4 Stories  
130,000 SF  
Cost : \$36,600,000

### Architecture

Provides connection to two adjacent buildings.  
New two story Entrance Lobby serves as the gateway to the hospital with interior/exterior fountain.  
Four triangular nursing wings surround a central Core.  
Architectural precast concrete wall panels.  
Four story structure is designed to support three additional floors.

### Mechanical Systems

Two roof top units serve each half of the building.  
Hot water radiant heat systems help control lobby spaces and glass curtain walls.  
Variable volume exhaust system installed with constant volume exhaust system to create isolation rooms where necessary.

### Structural Systems

Steel skeleton with composite columns on the first floor.  
Bolted flange plate moment connections are designed to resist lateral loads.  
Beam and Girder composite floor framing system with metal deck and 3 1/4" concrete slab.  
Continuous and spread footing foundation with 5" thick concrete slab on grade.

### Lighting/Electrical Systems

13.8kV feeding multiple 480/277V transformers.  
208/120V step down transformers supply load to interior fixtures.  
250kV emergency backup generator.  
Predominantly 277/120V fluorescent or compact fluorescent luminaries.

Philip Frederick  
Structural Option

<http://www.engr.psu.edu/ae/thesis/portfolios/2008/prkf109/>



# SWEDISH AMERICAN HEALTH SYSTEM



Philip Frederick  
Structural Option  
Advisor: Dr. Andres Lepage  
April 9<sup>th</sup>, 2008

Swedish American Hospital  
Heart and Vascular Center  
1400 Charles St, Rockford, IL

## **ACKNOWLEDGEMENTS:**

---

### **Swedish American Hospital:**

Glenn Evans

### **Perkins + Will Architects:**

Blaine Campbell

### **Simpson Gumpertz and Heger:**

John Thomsen

Michael Bolduc

Nik Vigener

### **Turner Construction**

Andy Pilipczuk

John Weaver

### **Penn State AE Faculty:**

Dr. Andres Lepage

Kevin Parfitt

Robert Holland

Moses Ling

Linda Hanagan

Andreas Phelps

\* A special thanks to all my friends and peers who were there to help me work through some of the problems I faced during this senior thesis.

**TABLE OF CONTENTS**

---

**EXECUTIVE SUMMARY** ..... 5

**EXISTING STRUCTURAL SYSTEM OVERVIEW** ..... 7

**CODES** ..... 9

**MATERIAL STRENGTHS** ..... 9

**FRAMING PLANS** ..... 10

**GRAVITY LOADS** ..... 12

**LATERAL LOADS** ..... 14

    WIND LOADS

    SEISMIC LOADS (BRACED FRAME)

**PROBLEM STATEMENT** ..... 17

**DEPTH STUDY** ..... 18

    GRAVITY FRAMING

    CASTELLATED BEAMS

    LATERAL SYSTEM

    BASE PLATES

    CONCLUSIONS

**CONSTRUCTION MANAGEMENT BREADTH STUDY**..... 31

    COST ANALYSIS

    CONSTRUCTION SCHEDULE

    CONCLUSIONS

**FAÇADE BREADTH STUDY** ..... 36

    EXISTING CONDITIONS

    PROPOSED SOLUTIONS

    CONCLUSIONS

**APPENDIX** ..... 42

## EXECUTIVE SUMMARY

---

Swedish American Hospital recently completed construction of the new Heart and Vascular Center, also known as the Heart Hospital. This structure is designed as a 7 story patient facility located in Rockford, Illinois. Although the building was designed as a 100' tall building, it currently only stands 4 stories tall with mechanical units on the roof enclosed by a mechanical screen wall. The final phase of construction would be to enclose the current roof into a 5<sup>th</sup> floor mechanical space and complete the remaining two stories.

The existing gravity system uses composite action between rolled wide flange beams and 3" metal deck with 3.25" of lightweight concrete. Shear studs connect the beams to the concrete and metal deck. Typical interior spans are 32'-0" with shorter spans found towards the perimeter of the building, typically 18'-0" or 22'-7". Typical beam sizes range from W12x14's to W27x146. The smaller W12's and W16's are found at the shorter 18'-0" and 22'-7" spans. Larger W18's and W21's are designed for the 32'-0" spans, or the shorter spans with heavier concentrated loads.

The largest beams, W27x146, are part of the existing moment frames acting as the lateral framing system. These members span 32'-0" and are connected using Bolted Flange Plate moment connections to W14x176 columns. Each moment frame typically spans the length of two bays (64'-0").

The purpose of this report is to determine the performance of an alternative lateral force resisting system as a part of the AE Senior Thesis. A braced frame is chosen as the new lateral system and a computer model was created in RAM Structural System to thoroughly analyze the structure's response to lateral loads from wind and seismic forces. Framing elements modeled in the program were connected together at each story level with a rigid diaphragm. In the model, columns were assumed to be pinned at the base. This is a conservative assumption and was also assumed by the structural engineer of record.

The proposed braced frame design is intended to reduce the story drift and overall displacement. A total of 10 chevron braces are situated on every floor with each frame spanning one bay. Hollow HSS members are used as the bracing members so they can be concealed in wall cavities instead of being exposed. W14x120 columns will replace the larger W14x176 columns from the moment frames. Beams in the braced frames are shear connected and are designed for only gravity loads, with one exception. Beams at the 2<sup>nd</sup> floor level will be moment connected to provide extra stiffness in case braces cannot be added on the first floor (lobby area).

Detailed analysis of the braced frame system reveals an improvement in stiffness by reducing drift from 3.41" (E-W) and 3.66" (N-S), with moment frames, to 1.45" (E-W) and 2.16" (N-S) with braced frames (values are from wind pressures). A displacement of 2.16" corresponds to an H/555 value compared to the accepted value of H/400 for wind. The switch to

Philip Frederick  
Structural Option  
Advisor: Dr. Andres Lepage  
April 9<sup>th</sup>, 2008

Swedish American Hospital  
Heart and Vascular Center  
1400 Charles St, Rockford, IL

braced frames also decreases the total tonnage of steel needed for construction. This decrease in tonnage will save money on material costs and time of construction.

Additionally, this report also investigates a moisture condensation problem observed at the window sills in the patient rooms. Construction drawings and window manufacturer details were analyzed to determine the possible causes of condensation. Possible repairs were then developed and presented as solutions to the existing problem. It was concluded that a relatively new product, called “Heat Trace” would be the most cost effective solution. Heat Trace works by running current through a wire to produce heat. The wire is attached to the interior sill surfaces and is covered with a prefabricated aluminum sill piece to create a heat sink. The applied heat will raise the temperature of the frame above the dew point for the interior air conditions.

## **EXISTING STRUCTURAL SYSTEM OVERVIEW**

---

### ***INTRODUCTION:***

The Swedish American Hospital, located in Rockford, IL, is phase 2 in a 3 phase construction project on the Swedish American Health Center. Phase 2 ended with the completion of the 4 story Heart Hospital (see cover page). The Heart Hospital is designed for a total of 7 floors of patient wings based on a Certificate of Need for the city of Rockford and the surrounding areas. Phase 3 of the construction process is to frame in the existing roof of the Heart Hospital creating a 5<sup>th</sup> floor (functioning as a mechanical floor) and continue on to complete the 6<sup>th</sup> and 7<sup>th</sup> floors above.

### ***FLOOR SYSTEM:***

The typical building floor framing system is made up of beams and girders acting compositely with a concrete floor slab. Floor sections show 3"-20 gauge LOK Floor galvanized metal deck with 3¼" of lightweight concrete (110 pcf) resting on the steel framing below. Composite action is achieved through 5" long ¾" diameter shear studs welded to the steel framing. Concrete is reinforced with 6x6-W5xW5 welded wire fabric. The span of the metal deck varies depending on the bay location. However, the direction is limited to east-west or northeast-southwest. This assembly has a 2 hour fire rating without the use of spray on fireproofing.

There is no "typical" bay in the structural framing system. However, columns located on the wings are spaced approximately 22'-7 ½" on center. Columns in the interior core area are spaced approximately 32'-0" on center with additional columns located around the core perimeter framing into the wings. The most common and longest span is 32'-0". Typical beam sizes range from W12x14's (typically spanning 10' to 12') to W27x146 (spans ranging from 22' to 32') with the larger beams acting as part of the moment framing system.

### ***ROOF SYSTEM:***

The roof framing system is very similar to the building floor framing system. Composite design is still used with 3 ¼" of lightweight concrete and 3"-20gauge LOK Floor metal deck on top of steel framing. Deeper steel beams and girders are used to help carry the heavier loads of the mechanical equipment on the roof.

The lobby roof is slightly different from the typical roof framing. It uses composite action but has a 1 ½" deep 20 gauge metal deck spanning north-south instead of the 3" metal deck used elsewhere on the building. Lower portions of the roof that see a heavier snow loads due to drift use a 3" deep 20 gauge metal deck.

### ***LATERAL SYSTEM:***

The lateral load resisting system consists of steel moment frames. The majority of the moment frames extend around the perimeter of the building with a few added moment frames on the interior to help stiffen the structure. Larger girders (W27x146's) are framed into columns (W14x176's) with bolted flange plate moment connections. The prefabricated steel members

were bolted in place rather than welded to eliminate the need for preheating of steel for welds. Shear walls were not part of the original design analysis; therefore, masonry cores such as the elevator and stairwell cores were not assumed to provide lateral support during the structural analysis.

***FOUNDATION:***

The basement footprint is approximately one half of the square footage of the first floor plan. Hence, there are two slabs on grade: one for the basement and one for part of the first floor. Each slab on grade is 5" thick normal weight concrete (145pcf) with 4x4-W5xW5 welded wire fabric reinforcement.

Interior steel columns rest on spread footings with an allowable soil bearing capacity of 4ksf. Exterior columns and basement walls rest on continuous strip footings. Reinforced concrete pilasters are located where exterior columns rest on the basement wall. Footings below columns in the interior core area extend approximately 18' deep whereas the perimeter strip footings and footings located beneath the wings extend approximately 8' deep. All footings are required to extend a minimum of 4' deep for frost protection.

***COLUMNS:***

Columns are laid out on two different intersecting grids: one running east-west and the other running northwest-southeast. All columns are ASTM A992 Grade 50 wide flange steel shapes. Columns are spliced between the 3<sup>rd</sup> and 4<sup>th</sup> floor. Columns acting as part of a moment frame are spliced 5'-6" above the 3<sup>rd</sup> floor elevation. Columns acting only as gravity columns are spliced 4'-6" above the 3<sup>rd</sup> floor elevation. All interior columns that extend to the basement level are also spliced 5'-6" above the 1<sup>st</sup> floor elevation. Future columns for the 6<sup>th</sup> and 7<sup>th</sup> floors are designed to be spliced with existing columns at the 5<sup>th</sup> floor elevation (current mechanical floor and roof).



## **CODES**

---

### ***ORIGINAL DESIGN CODES:***

- International Building Code (IBC) 2003
  - with City of Rockford, IL amendment
- American Society of Civil Engineers (ASCE)
  - ASCE 7-02 - Minimum Design Loads for Buildings and Other Structures
- American Concrete Institute (ACI)
  - ACI 318-02 - Building Code Requirements for Structural Concrete
  - ACI 530-02 – Building Code Requirements for Masonry Structures
- American Institute of Steel Construction (AISC)
  - LRFD 1999 - Load and Resistance Factor Design Specification for Structural Steel Buildings
  - AISC 341-02 – Seismic Provisions for Structural Steel Buildings

### ***THESIS DESIGN CODES:***

- International Building Code (IBC) 2006
- American Society of Civil Engineers (ASCE)
  - ASCE 7-05 - Minimum Design Loads for Buildings and Other Structures
- American Concrete Institute (ACI)
  - ACI 318-05 – Building Code Requirements for Structure Concrete

## **MATERIAL STRENGTHS**

---

### ***CONCRETE:***

Normal Weight Concrete (columns, walls, foundations, slabs on grade).....	4000psi
Light Weight Concrete (floor slabs on metal deck).....	4000psi
Reinforcement .....	60ksi

### ***STRUCTURAL STEEL:***

Wide Flanges and Channels .....	50ksi
Angles, Bars and Plates.....	36ksi
Hollow Structural Sections (HSS).....	46ksi
Bolts (A325X or A490X).....	3/4" dia
Shear Studs (5" long).....	3/4" dia

### ***MASONRY:***

Design Strength ( $F'_m$ ).....	2000psi
Block.....	4000psi

## EXISTING FRAMING PLANS

---

### *TYPICAL FRAMING PLAN:*

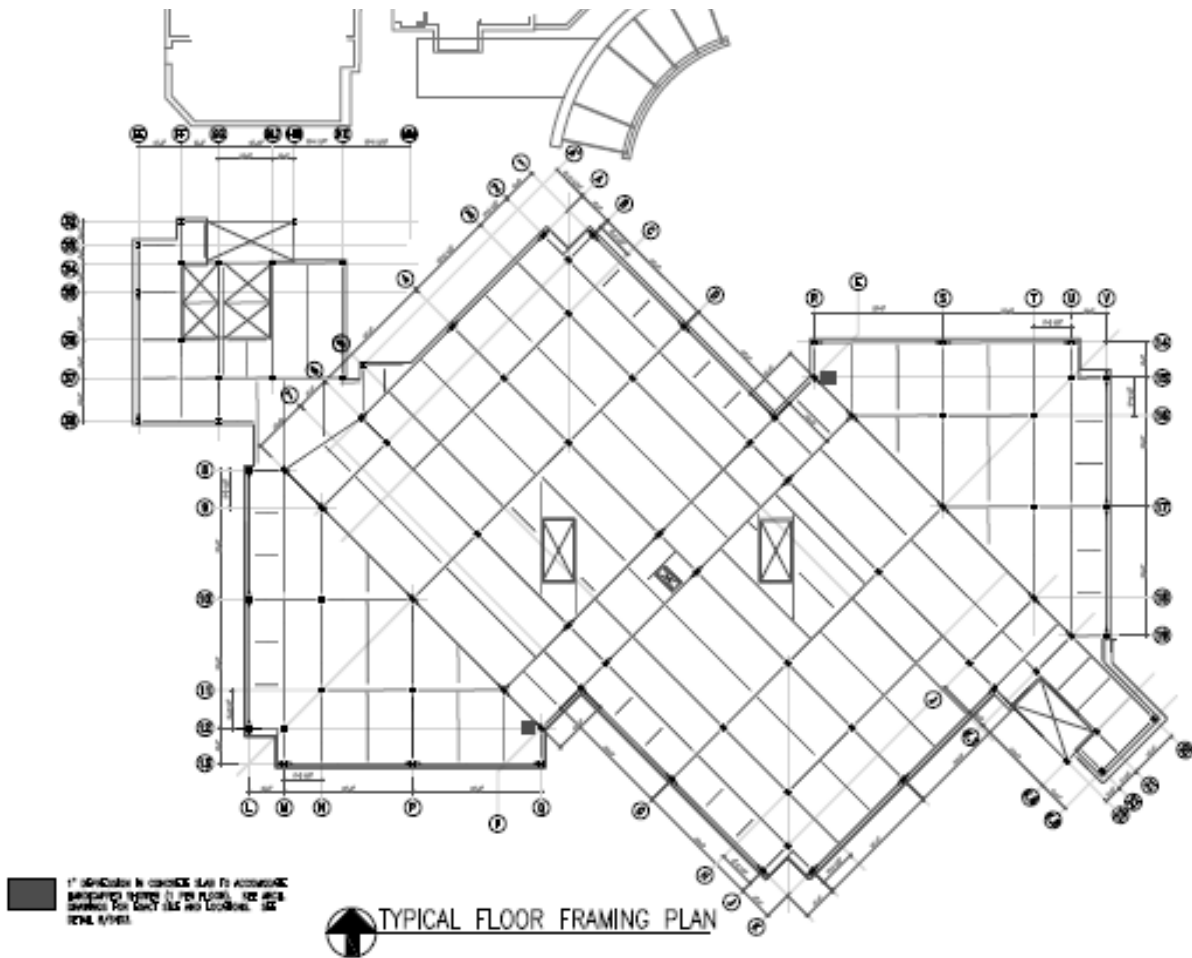

Figure 1: Typical Framing Plan

**EXISTING LATERAL FRAMING PLAN:**

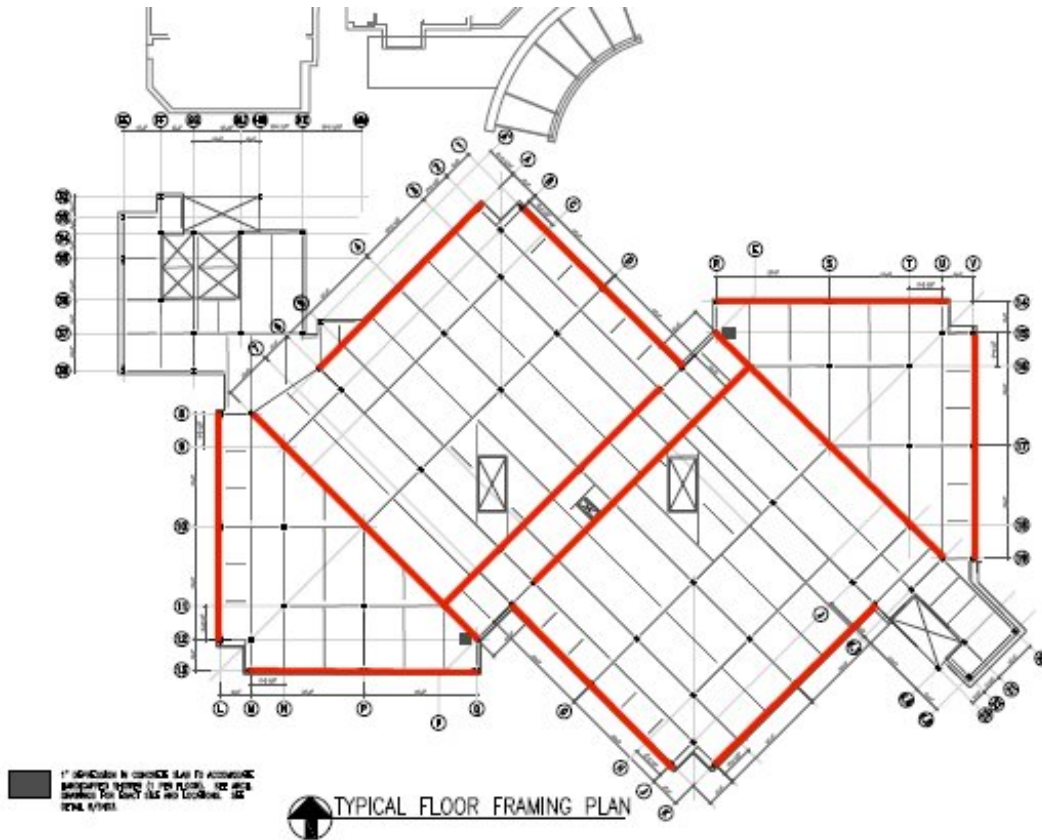

Figure 2: Framing Plan with Highlighted Moment Frames  
\*Typical moment frames are outlined in RED.

## GRAVITY LOADS

### FLOOR LIVE LOADS

Loaded Area	Building Design Load	ASCE 7-05 Section 4
Basement Floor	100 psf	Table 4-1
First Floor	100 psf	Table 4-1
Typical Floors (2 <sup>nd</sup> , 3 <sup>rd</sup> , 4 <sup>th</sup> , 6 <sup>th</sup> , 7 <sup>th</sup> )	80 psf	Table 4-1
Mechanical/Roof (5 <sup>th</sup> Floor)	150 psf	Set by SAH*, Engineers
Stairwells	100 psf	Table 4-1
Roof (8 <sup>th</sup> Future Roof)	25 psf	ASCE 7-05 Section 7 (Snow)

\* SAH – Swedish American Hospital

### ROOF SNOW LOADS (LIVE LOAD)

Item	Design Load	Code References
Roof Live Load	25 psf	ASCE 7-05 Section 7
Ground Snow Load	30 psf	ASCE 7-05 Figure 7-1
Additional Drift Load	50.4 psf	ASCE 7-05 Section 7-7
Exposure Factor ( $C_e$ )	1.0	ASCE 7-05 Table 7-2
Importance Factor ( $I$ )	1.2	ASCE 7-05 Table 7-4
Thermal Factor ( $C_t$ )	1.0	ASCE 7-05 Table 7-3

### DEAD LOADS

#### TYPICAL FLOORS 1 THROUGH 4 AND FUTURE FLOORS 6 AND 7

Item	Design Load
Partitions	0 psf
Steel Deck with LWC Slab	48 psf
Ponding due to Deflection	5 psf
Steel Self Weight	15 psf
MEP, Misc.	12 psf
<b>Total</b>	<b>80 psf</b>

#### 5<sup>TH</sup> FLOOR (ROOF/MECHANICAL)

Item	Design Load
Partitions	0 psf
Permanent Equipment	0 psf
Steel Deck with LWC Slab	48 psf
Ponding due to Deflection	5 psf
Steel Self Weight	15 psf
MEP, Misc.	12 psf
<b>Total</b>	<b>80 psf</b>

#### 8<sup>TH</sup> FLOOR (FUTURE ROOF) \*

Item	Design Load
Steel Deck with LWC Slab	48 psf
Ponding due to Deflection	5 psf
Steel Self Weight	15 psf
MEP, Misc.	12 psf
<b>Total</b>	<b>80 psf</b>

Philip Frederick  
Structural Option  
Advisor: Dr. Andres Lepage  
April 9<sup>th</sup>, 2008

Swedish American Hospital  
Heart and Vascular Center  
1400 Charles St, Rockford, IL

*OTHER AREAS (LOBBY ROOF, STAIR TOWER ROOF) \**

<b>Item</b>	<b>Design Load</b>
Metal Deck, Insulation, Roofing	25 psf
Steel Self Weight	15 psf
MEP, Misc.	5 psf
<b>Total</b>	<b>45 psf</b>

*WALL DEAD LOADS*

<b>Item</b>	<b>Design Load</b>
Exterior Wall Precast Panel	85 psf
Exterior Wall Brick	50 psf
Exterior Aluminum Curtain Wall	15 psf
Shaft Walls around openings	20 psf
Stair Walls around openings	80 psf

\* Snow mass is not included in Dead Loads, but a 5 psf snow load is included for seismic massing (ASCE 7-05 Section 12.7.2).

## LATERAL LOADS

### WIND FORCES:

For wind pressures, the windward pressure acting along the height of the structure is in the form of a parabolic curve. A conservative assumption is to break the curve into a rectangular grid and find the effective pressure acting on an individual story. Windward pressures are calculated using equation 6.19 in ASCE 7-05 Section 6 (see the Wind Load Tables below for wind story shears). Leeward pressure is assumed to be a constant along the back of the building and calculated using the total building height. Wind pressures are calculated in two main directions (usually acting perpendicular to the building face). Base shears resulting from wind for the Heart Hospital were 1045k (N-S direction) and 703k (E-W direction). Included in these values is a load factor of 1.6 for the applicable load combinations.

Level	Total Height	K <sub>z</sub>	q	Wind Pressures (psf)					
				N-S Windward	N-S Leeward	N-S Side Wall	E-W Windward	E-W Leeward	E-W Side Wall
Roof	99.17	1.26	25.54	21.86	-10.79	-15.10	22.02	-8.71	-15.25
7	85.83	1.225	24.83	21.38	-10.79	-15.10	21.54	-8.71	-15.25
6	72.50	1.18	23.92	20.76	-10.79	-15.10	20.92	-8.71	-15.25
5	52.5	1.1	22.30	19.67	-10.79	-15.10	19.81	-8.71	-15.25
4	39.17	1.04	21.08	18.84	-10.79	-15.10	18.98	-8.71	-15.25
3	25.83	0.94	19.05	17.47	-10.79	-15.10	17.60	-8.71	-15.25
2	12.5	0.85	17.23	16.24	-10.79	-15.10	16.35	-8.71	-15.25

Level	Eff. Height	Wind Design (NS - EW)							
		Load (kips)		Shear (kips)		Moment (ft-k)		Factored Load (1.6W)	
		N-S	E-W	N-S	E-W	N-S	E-W	N-S	E-W
		230'	165'	230'	165'	230'	165'	230'	165'
Roof	6.67	50	34	0	0	4963	3352	80	54
7	13.33	99	67	50	34	8528	5757	159	107
6	16.67	122	82	149	101	8853	5969	195	132
5	16.67	119	80	272	183	6239	4198	190	128
4	13.33	92	62	390	263	3608	2422	147	99
3	13.33	89	59	482	325	2292	1534	142	95
2	12.92	82	55	571	384	1027	684	131	88
1	6.25	39	26	0	0	0	0	62	41
Total	99.15	653	439	653	439	35509	23916	1045	703

Table 1: Effective Wind Pressures and Story Shears

**SEISMIC FORCES – BRACED FRAME:**

For seismic loading, the total base shear is calculated using ASCE 7-05 Sections 11 and 12. The Heart and Vascular Center has a base shear of approximately 979k. This base shear is divided over the entire story height. Vertical distribution of seismic forces is based on the height and weight of each story over the sum of the heights and weights for each floor. This effective story force is assumed to be taken at the floor level of each story. Story forces are smaller at the lower levels but increase with building height.

**SEISMIC LOAD TABLE**

Item	Design Value	Code Reference
Occupancy Category	IV	ASCE 7-05 Table 1-1
Site Class	D	* From Geotechnical Report
Spectral Acceleration for Short Periods ( $S_s$ )	0.17g	* From Geotechnical Report
Spectral Acceleration for One Sec. Periods ( $S_1$ )	0.06g	* From Geotechnical Report
Design for Short Periods ( $S_{ds}$ )	0.1813	ASCE 7-05 Section 11.4.4
Design for One Sec. Periods ( $S_{d1}$ )	0.096	ASCE 7-05 Section 11.4.4
Seismic Design Category	C	ASCE 7-05 Section 11.6.1.1
Seismic Force Resisting System	Ordinary Steel Concentrically Braced Frames	ASCE 7-05 Table 12.2-1
Response Modification Factor (R)	3.25	ASCE 7-05 Table 12.2-1
System Overstrength Factor ( $\Omega$ )	3.0	ASCE 7-05 Table 12.2-1
Deflection Amplification Factor ( $C_d$ )	3.0	ASCE 7-05 Table 12.2-1
Importance Factor	1.5	ASCE 7-05 Table 11.5-1
Approximate Period ( $T_a$ )	0.627	ASCE 7-05 Section 12.8.2.1
Period (T)= $C_u \cdot T_a$	1.0659	ASCE 7-05 Section 12.8.2.2
Seismic Response Coefficient ( $C_s$ )	0.0416	ASCE 7-05 Section 12.8.1.1
Building Weight (kips)	23560	* From Massing Calcs
Design Base Shear (kips)	979	

Table 2: Seismic Load Table

***VERTICAL DISTRIBUTION OF SEISMIC LOADS***  
***ASCE 7-05 SECTION 12.8.3***

Level	h (in ft)	W in kip	$w_x h_x^k$	$C_{vx}$	F <sub>x</sub> (k)
8th floor (future roof)	99.17	2568	927548	0.24	231.59
7th floor (future)	85.83	2977	893669	0.23	223.13
6th floor (future)	72.50	3376	816328	0.21	203.82
5th floor mech	52.50	4047	647139	0.17	161.58
4th floor	39.17	3091	339581	0.09	84.79
3rd floor	25.83	3342	215423	0.05	53.79
2nd floor	12.50	3200	81379	0.02	20.32
1st floor	0.00	1049	0	0.00	0.00
		23650	3921066		979

Table 3: Vertical Distribution of Seismic Forces

Design Base Shear (V) = 979 k  
 k (by interpolation) = 1.2812



## **PROBLEM STATEMENT**

---

The Swedish American Hospital's new Heart and Vascular Center is currently a 4 story steel framed structure located in Rockford, IL. The completion of the 4 story structure was the end of phase 2 in a 3 phase construction project on the Swedish American Campus. The original design for the Heart Hospital was a 7 story structure with a large mechanical space located on the 5<sup>th</sup> floor (the current roof area). The completion of the final 3 stories will be phase 3 of the construction plan.

The initial design for 7 stories is based on a "Certificate of Need" for the city of Rockford and the surrounding area. This requires the hospital to provide space for a certain number of patients stated in the certificate. However, the "certificate of need" takes into account a future prediction of the growing population for that area. In the case of the Heart Hospital, other nearby hospitals would be able to accommodate any increase in patients due to an increased population growth. Hence, they only constructed the hospital to accommodate a certain number of patients based on the current population of the surrounding area.

During a visit to the Heart Hospital, the idea to study the significant structural changes and cost savings for only the 4 story structure in comparison to the planned 7 story structure was proposed. However, the 4 story structure would not meet the "certificate of need" requirements set by the city of Rockford.

Instead, it was agreed upon to study the potential cost savings and schedule differences of an alternative gravity framing system and lateral framing system for the proposed 7 story structure. From a previous study completed in the fall, it was concluded that two gravity systems were viable options for floor systems (composite steel beams and girders or post tensioned concrete floor slabs). Also, to help minimize member sizes, story drift, and limit the need for large moment connections, braced frames are proposed in place of the existing moment frames. Using the IBC 2006 building code (citing ASCE 7-05 and ACI 318-05) and computer modeling software (Ram Structural System), it will be determined if a change in the structural framing layout or lateral system could provide an economic alternative to the designed 7 story structure.

Concurrently, a façade study will be completed focusing on moisture condensation occurring on the interior window sills in the patient rooms. This topic of study was suggested during a visit to the site. Apparently, Swedish American has been observing moisture condensation collecting on the interior window sills during the winter months. The façade study will focus on the existing window conditions and possible causes for moisture condensation in the patient rooms. Finally, potential repairs will be developed and offered as solutions to resist condensation.

## **DEPTH STUDY: GRAVITY ANALYSIS AND LATERAL REDESIGN**

---

Concrete and steel are the two predominant building materials used in Rockford, IL, and the surrounding area. Contacts from Turner Construction have mentioned that Turner has worked on a number of projects in the area that use one material or the other, suggesting that neither one is used more frequently than the other. However, recently there has been a strong push for using steel moment frames in the construction of medical facilities. In the October 2007 issue of *Modern Steel Construction*, the article “A Tale of Two Projects” explains this practice of utilizing Steel Moment Frames in Healthcare Facilities.

“...Most of the Health-Care Facilities we [Simpson Gumpertz and Heger] have designed during the past decade share the same lateral force resisting system: a steel moment frame. This preference is the result of special design requirements for “essential facilities,” as well as the unique combination of a need for long life and renovation flexibility in health-care construction.”

Due to this preference of using steel to create flexible open plans, it was determined that the proposed alternative system will be designed in steel, not concrete. Using steeling framing, instead of post tensioned concrete, will remove the need for shear walls that might interrupt the plan and also eliminate the need for finding a local contractor experienced with post tensioned construction.

### ***GRAVITY FRAMING:***

With steel selected as the material of choice, alternative gravity layouts (using composite steel beams and girders) were designed and analyzed. These alternative layouts focused on reducing the number of beams and/or columns needed for floor construction. The floor plan of the building was divided into 2 different sections: the floor framing section and the wing framing section. (See Figure 3 for layouts of the framing sections)

Existing framing sections were modeled in Ram Structural System. The alternative framing plans for each section were also modeled in Ram Structural System and then compared to the existing sections. Figure 4 shows the existing framing for both sections. (Note: due to symmetry, only half of the floor section and one wing section was analyzed). These results were then doubled and multiplied by 7 to account for symmetry and the 7 stories. Table 2 summarizes the number of members and weights for each framing layout and calculates their total weight including columns. Shear studs are accounted for in the overall weight assuming 10lbs of steel per stud.

(See Appendix A for layouts of the alternative framing layouts for the floor section and the wing section)

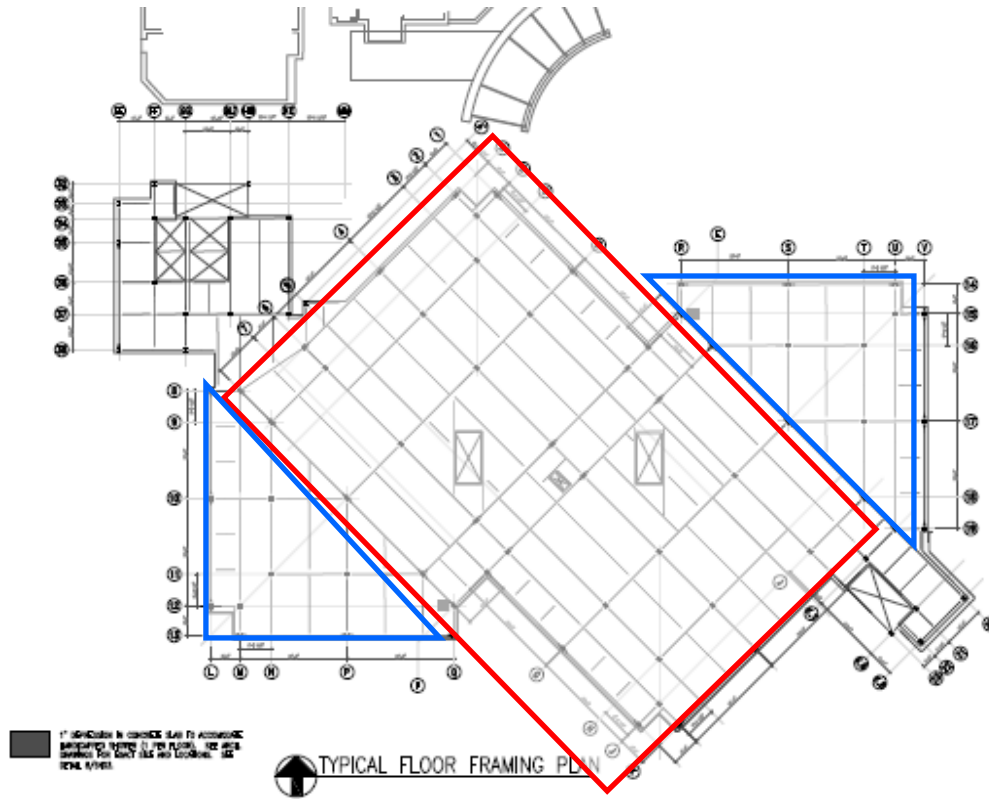

Figure 3: Framing Sections (Floor in Red, Wings in Blue)

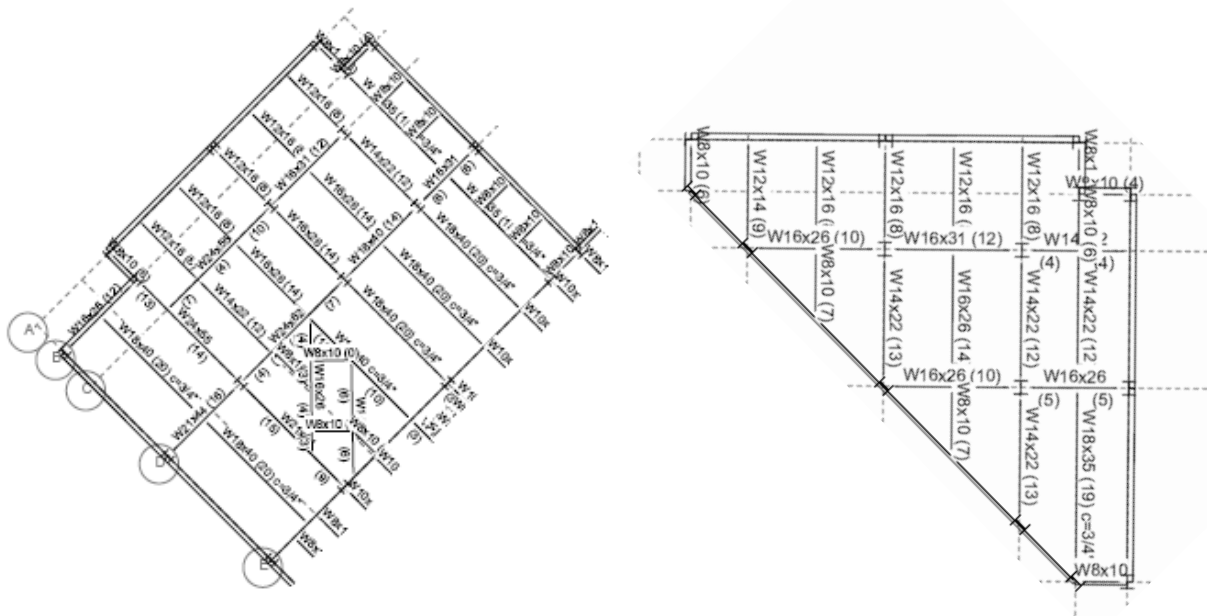

Figure 4: Existing Framing Sections (Floor on left, Wing on right)

Gravity Framing							
	Floor Framing			Column Framing		Total Weight	# of Pieces
Floor Plan	# of Members	Studs	Weight (lbs)	# of Members	Weight (lbs)	(assume 10lb/stud)	
Existing Floor	701	7813	399802	42	87242	565174	743
Floor Alt 1	687	8013	445443	30	69788	595361	717
Floor Alt 2	589	7575	476404	24	59157	611311	613
Floor Alt 3	603	7546	463162	30	67614	606236	633
Floor Alt 4	575	7655	488753	18	50655	615958	593
Wing Existing	322	3088	120742	24	41852	193474	346
Wing Alt 1	266	3288	183358	12	19618	235856	278
Wing Alt 2	210	3004	177886	12	22388	230314	222
Wing Alt 3	196	3094	211792	6	8502	251234	202
Wing Alt 4	196	3074	190376	6	13886	235002	202

Table 4: Existing Framing Sections (Central on left, Wing on right)

The analysis performed by Ram Structural System confirms that the existing sections (although having more members) are the lightest overall sections when compared to the alternative layouts developed in the report.

**CASTELLATED BEAMS:**

To explore the efficiency of the gravity system further, the question is asked ‘What would it take to reduce the weight of the gravity framing?’ Castellated Beams are the answer.

CMC Steel Products ([www.cmcsteelproducts.com](http://www.cmcsteelproducts.com)), located in Rockwall, Texas, is the leading manufacturer of cellular beams in the U.S. CMC claims castellated beams (or Smartbeams) are most efficient when used for spans between 40’-60’. Advantages of using Smartbeams include: less members for faster erection, lowers floor to floor height by passing ducts through openings in web, and increased stiffness improving vibration characteristics. Some disadvantages of Smartbeams are: expensive compared to typical rolled steel shapes, longer fabrication time, and difficult to find (many steel fabricators cant/wont manufacture castellated beams because they are rarely used in typical construction and are not cost effective).

CMC provides design programs for various castellated beams in composite and non-composite floor systems. The Castellated Composite Design Program was used to analyze a castellated beam floor system at Swedish American Hospital. The program is an interactive Excel spreadsheet. The program requires user input for: span length, spacing, loading, and composite properties. After the required input is entered, a trial beam size can be selected from a

pull-down menu (i.e.: CB27x50). Below the menu, the root beam (W18x50) is listed. At the bottom of the spreadsheet, 5 interaction equations are listed (bending, web post, shear, concrete and pre-composite) and 2 deflection equations are listed (pre-composite and live load deflections). Larger trial CB members should continued to be selected until all of the interaction equations are satisfied (values should be less than or equal to 1.0). If the first trial CB member satisfies all the equations, then try selecting lighter CB shapes to maximize the efficiency of the design.

For the Swedish American Hospital project, it was decided to compare the existing gravity floor section layout (Floor Existing) with the floor section alternate #4 layout (Floor Alt #4). The wings were neglected for ease of calculation. Notice that using typical rolled steel shapes, the existing floor section weighs is 565,174 lbs, whereas, the floor alt #4 section weighs 615,958 lbs.

Figure 5 highlights the beams and girders on the floor alt #4 plan that will be replaced with castellated beams. The beams span a distance of 40.5' and the girders span distances of 32' and 22.625'. Castellated beams and girders for these spans were analyzed for the Typical Floor, the Mechanical Floor, and the Roof (all having different loads requiring minor modifications to the imposed loadings). Due to symmetry, only half of the Floor Alt #4 plan is shown.

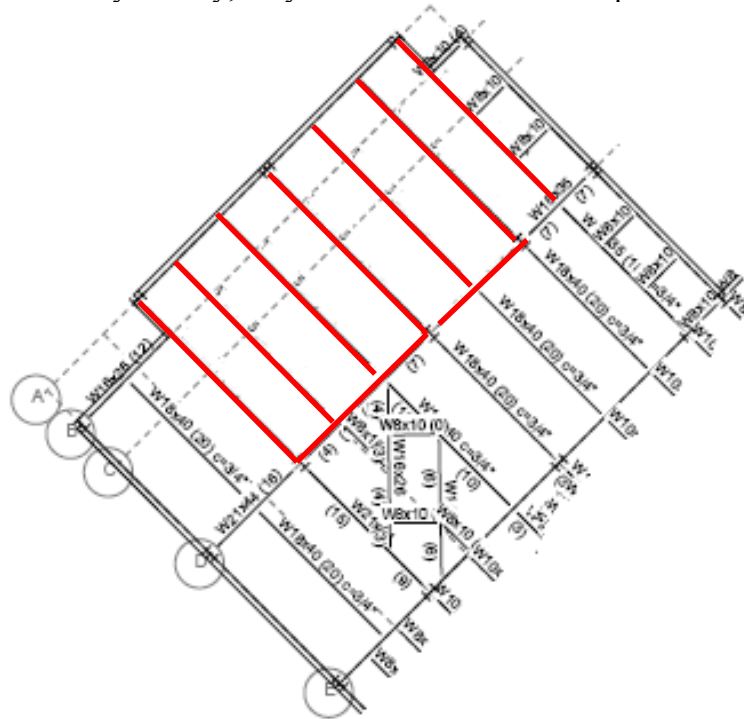

Figure 5: Castellated Beams and Girders

Using the design spreadsheet provided by CMC Steel Products, the lightest weight CB members were found for each span on each floor. (See Appendix B for a sample spreadsheet). After all the castellated beams were designed, the total weight of the new castellated beams was calculated to be 205,881 lbs. The total weight of the wide flange beams and girders they replaced was then calculated and found to be 262,462 lbs. The new corresponding weight of the floor alt #4 section with castellated beams was then calculated as shown below:

$$615958 \text{ lbs} - 262462 \text{ lbs} + 205881 \text{ lbs} = 559337 \text{ lbs} < 565174 \text{ lbs} \quad *OK$$

(Alt #4 Wt)	(Ex. Wide	(CB Wt)	(CB Floor	(Ex. Floor
	(Flange Wt)		System Wt)	System Wt)

(See Appendix C for detailed calculations of proposed castellated beam floor system)

Therefore, it is possible to decrease the weight of the floor system, but at what cost? R.S. Means lists minimum and maximum values for unit cost/ton for castellated beams above and below 50plf. Taking the average of the minimum and maximum values for each category and multiplying by the corresponding tonnage, a rough estimate of \$595,296 is obtained for the castellated beams. In comparison, using a unit cost of \$.44/ lb of steel for rolled wide flange shapes yields a rough estimate of \$427,715 for the wide flange beams replaced by the castellated beams. This is an increase of \$167,581 to use castellated beams in place of wide flange beams and only saves approximately 5,837 lbs of structure weight. (See Appendix D for a copy of the R.S. Means sheet and rough cost estimate calculations)

***CONCLUSIONS:***

Therefore, it is concluded that although the weight of the gravity floor system can be reduced, it is not cost effective. In this instance, castellated beams are not a reasonable alternative and the Structural Engineer used the lightest cost effective system.

**LATERAL SYSTEM:**

When designing the existing lateral force resisting system, the engineer of record assumed the lateral columns were pinned at the base. This is a conservative design assumption and will be copied for the proposed braced frame design.

The ground floor (1<sup>st</sup> floor) of the Heart Hospital is predominantly lobby space and has a very open architectural plan. Therefore, installing braced frames in the first floor is not an aesthetically pleasing solution. Similarly, the 5<sup>th</sup> floor (current roof area) houses the mechanical equipment and will have a very open floor plan. Originally, braces were left out of the 5<sup>th</sup> floor, but were later added to eliminate any vertical stiffness irregularities. It is assumed the mechanical equipment can be designed around the braced frames on the 5<sup>th</sup> floor.

Trial brace sizes are selected by analyzing a typical braced frame in SAP. For this analysis, it was assumed 4 braced frames would resist the lateral loads in each principle direction (X and Y). Each frame would take approximately 25% of the total lateral load. A simple 2-D frame with chevron braces was modeled in SAP to determine the maximum tension and compression forces in the braces. HSS members will act as the bracing members and the AISC Steel Construction Manual (13<sup>th</sup> ed.) is used to select the required HSS sizes. (See Appendix E for a printout of the SAP model)

The chevron braces were then added in the Ram Structural System model (with pinned bases). The trial brace sizes were assigned and the model was analyzed in Ram Frame. Wind and seismic loads were entered into the model as user defined unfactored loads. The required factored load combinations from ASCE 7-05 were then entered as individual load combinations in the model. The following load cases were analyzed:

- 1) 1.4(D)
- 2) 1.2(D) + 1.6(L) + 0.5(Lr)
- 3) 1.2(D) + 1.6(W<sub>N-S</sub>) + (L) + 0.5(Lr)
- 4) 1.2(D) + 1.6(W<sub>E-W</sub>) + (L) + 0.5(Lr)
- 5) 1.2(D) + 1.0(E<sub>N-S</sub>) + 0.3(E<sub>E-W</sub>) + (L)
- 6) 1.2(D) + 0.3(E<sub>N-S</sub>) + 1.0(E<sub>E-W</sub>) + (L)
- 7) 0.9(D) + 1.6(W<sub>N-S</sub>)
- 8) 0.9(D) + 1.6(W<sub>E-W</sub>)
- 9) 0.9(D) + 1.0(E<sub>N-S</sub>) + 0.3(E<sub>E-W</sub>)
- 10) 0.9(D) + 0.3(E<sub>N-S</sub>) + 1.0(E<sub>E-W</sub>)
- 11) Accidental Torsion Moment (see Table 5 below)

\* Load Cases are taken from ASCE 7-05 Chapter 2 (modified by seismic provisions in Chap 12). Swedish American Hospital has a Type 5 horizontal structural irregularity. Therefore, special requirements assigned in Section 12.5.3 apply (100%E<sub>1</sub> + 30%E<sub>2</sub>)

After all the loads and load cases were entered into the model, a preliminary analysis was run. The Story Displacements from the analysis for each floor were then checked against the

accepted  $H/400$  value for wind. Story Displacements were calculated using unfactored load cases. For an average story height of 13.3', an acceptable drift value is 0.40". Similarly, for a total building height of 100', an acceptable total drift value would be 3.0". Analyzing the initial Story Displacement output from RAM, it was apparent that the brace and column sizes needed to be increased to provide more stiffness and reduce drift. Also, with braces only installed on the upper floors (2 through 7), there was a significant story drift between the ground floor (1<sup>st</sup> floor) and the 2<sup>nd</sup> floor. To solve this problem, a moment frame was created on the first floor of the lateral frames. The existing beam on the 2<sup>nd</sup> floor level (previously a beam with shear connections) was replaced by a lateral beam with fixed moment connections at the ends. This change in framing provided additional stiffness to help reduce the story drift between the 1<sup>st</sup> and 2<sup>nd</sup> floors. (See Figure 6 for a typical lateral frame)

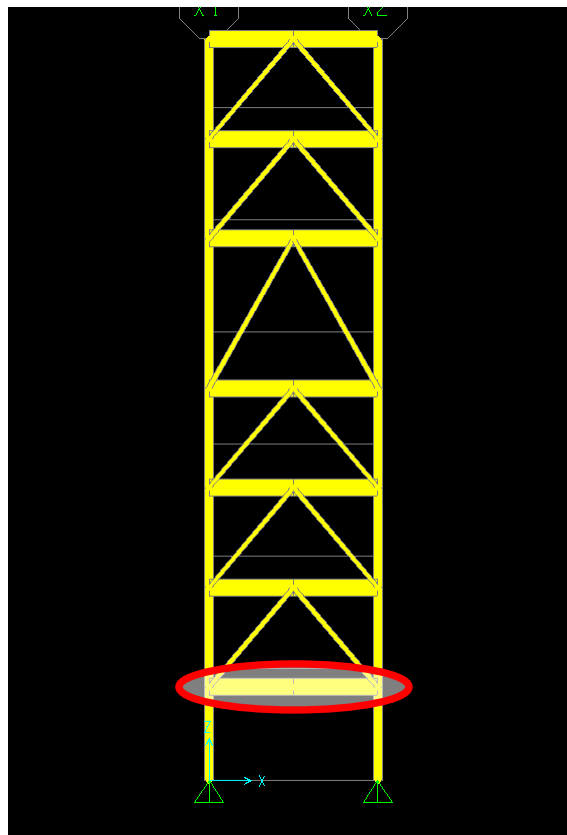

Figure 6: Typical Frame Analyzed in SAP (Preliminary Analysis)  
(Gravity beam changed to Lateral beam circled in RED)

During the analysis, it was determined that braced frames were needed on the 1<sup>st</sup> floor to further limit the drift between the ground floor (1<sup>st</sup> Floor) and the 2<sup>nd</sup> floor. If braced frames could be added to the First Floor, it could significantly reduce the size of the columns and lateral beams necessary for achieving the same Story Displacements. Looking at the First Floor Architectural Plan, a maximum of 3 braced frames can be added with minimal impact on the existing floor plan. Figure 7 (below) shows a typical architectural floor plan with the locations of



braced frames outlined in red. Areas where a braced frame was added on the First Floor, the frame is outlined in green.

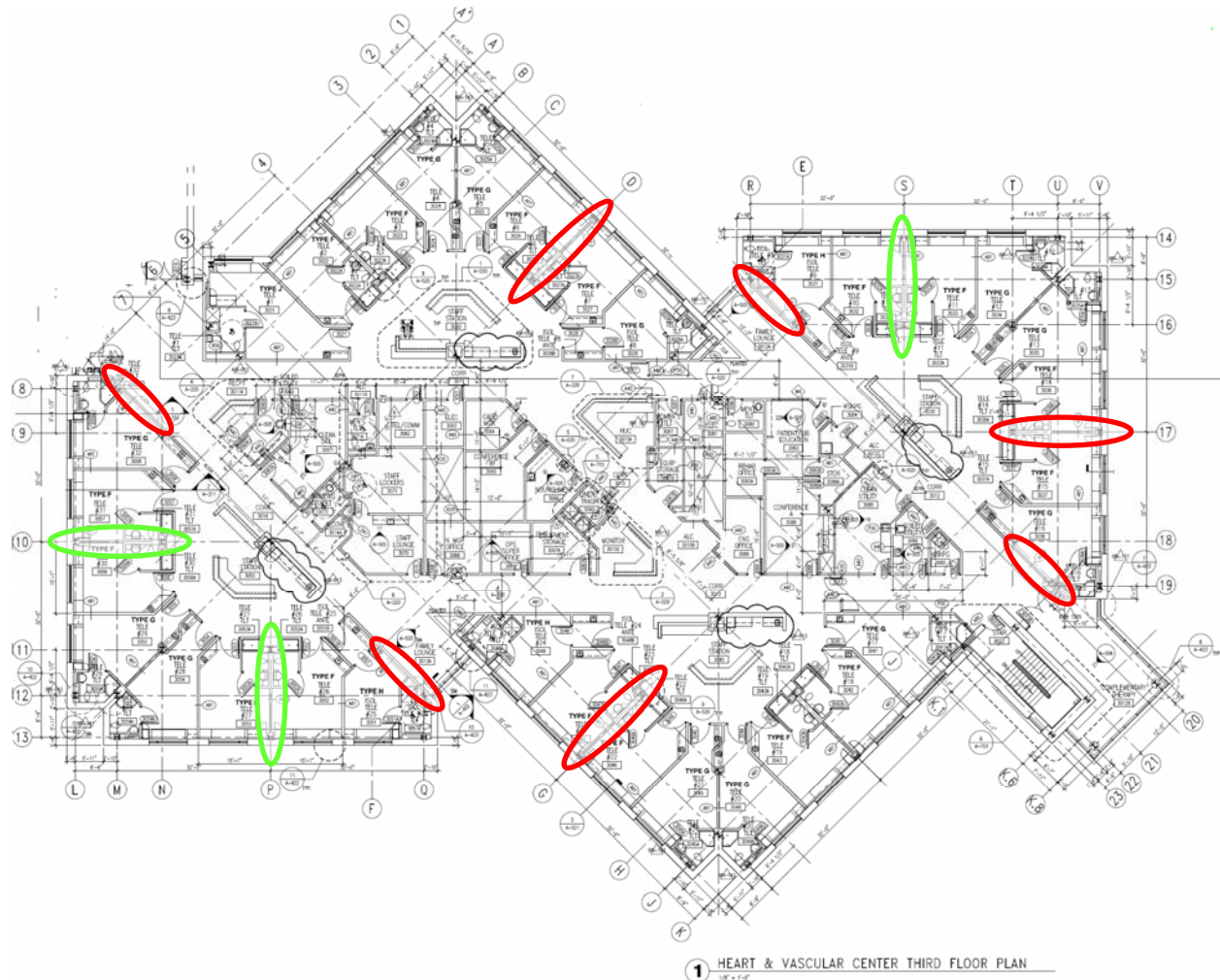

Figure 7: Architectural Floor Plan outlining areas with Braced Frames

After the required changes were made to the Ram Frame model, a second analysis was run. This process was repeated multiple times with the sizes of the columns, braces, and/or lateral beams increasing slightly each time. Story Displacements of each analysis were checked instead of Strength. Story Displacements were used to check the initial design because it is common for serviceability to control over strength for steel design. Each iteration was analyzed and updated until the Story Displacements for the design meet the  $H/400$  limit for wind.

This final design (noted as Design A) was then analyzed with the factored load combinations set in the RAM model (with pinned bases). The resulting forces were summarized in an Excel Spreadsheet to determine the maximum design forces for the columns, braces and beams (see Appendix F for pinned Excel Spreadsheet). Columns were analyzed using axial

forces ( $P_u$ ) and moments ( $M_u$ ). The effective axial force on a column ( $P_{eff}$ ) can then be calculated using the equation:

$$P_{eff} = P_u + (24/X) * M_u, \text{ where } X = \text{the depth of the column (d=14" for this analysis)}$$

Beams were analyzed using maximum moments and shear values, and Braces were analyzed using maximum axial tension and compression values.

After the summery table was completed in Excel, the maximum forces in each member were then compared to the corresponding allowable forces listed in the AISC Steel Construction Manual. In cases where the force in a member exceed the corresponding allowable force listed in the Steel Manual, the member was updated to larger member that is capable of withstanding the design force. These changes are highlighted blue in the spreadsheet and the corresponding members were updated in the RAM model. After all the changes were made to the RAM model, the updated design (noted as Design B) was analyzed.

After checking the member forces from the factored load combinations, it was determined that the forces found in Design B were below the allowable forces listed in the Steel Manual. Therefore, Design B meets the requirements for Strength Design. The Story Displacements were then checked for Design B (using unfactored load combinations) to confirm that serviceability was not an issue. The Story Displacements from RAM confirm that the serviceabililty due to drift satisfies the H/400 limit for wind. (See Appendix G for the final Story Displacements)

#### ***BASE PLATES:***

Although all the column bases were assumed to be pinned for the initial design, closer inspection of the base plates under the lateral columns shows the potential to carry some moment capacity. (See Appendix H for base plate details) This partial fixity will provide some stiffness against lateral loads and story displacement. First, the moment capacity of the existing base plate must be calculated. The following equation:

$$M_u = \phi_b F_y I / c$$

yields a moment capacity of 432 kip-ft for the existing 2" thick base plate. If the existing RAM model (with pinned bases) was modified with fixed bases instead of pinned, large moment forces would be present at the base of the columns. This new model is designated as 'RAM model with fixed bases'. (See Appendix I for an Excel Spreadsheet listing the frame member forces assuming fixed bases) From the spreadsheet, it is apparent that Frames 1 and 4 (also Frames 5 and 8 due to symmetry) are the only frames that don't experience moments larger than the calculated moment capacity of the base plates. If the bases of these frames (Frame 1, 4, 5 and 8) are modeled as fixed connections in the pinned model, there is a small increase in the overall stiffness of the structure, limiting building drift slightly.

A further calculation shows that a 2.25" thick base plate with the same dimensions has a moment capacity of 615 kip-ft. This moment capacity is larger than all of the moment forces calculated at the column bases in the RAM model (with fixed bases). By increasing the moment capacity of the base plate connection, each frame is stiffened. Stiffer frames are able to carry more load and are more resistant to drift.

#### ***RESULTS AND CONCLUSIONS:***

The existing lateral force resisting system is designed with perimeter moment frames. W14x176 columns and W27x146 beams are required to handle the large forces generated by the lateral loads. Modeling the existing system, assuming pinned bases, story drift between the ground floor (1<sup>st</sup>) and the 2<sup>nd</sup> floor was larger than the typical H/400 limit. Also, the overall story displacement at the roof was close to the H/400 limit.

The proposed braced frame design is intended to reduce the story drift and overall displacement. A total of 10 chevron braces are situated on all upper floors with each frame spanning one bay. The final braced frame design (Design B) uses rolled W14x120 shapes as columns and W21x68 members as 2<sup>nd</sup> floor beams with moment connections. The beam sizes on the upper floors are determined by the gravity design, completed in RAM. Beams in the braced frames span approximately 13'-3", whereas a typical column extends 13'-4" between floors with the longest un-braced length equaling 20'-0" at the 5<sup>th</sup> floor. Hollow Tube (HSS) members are used as the bracing elements. HSS members range from HSS6x6x3/8 to HSS8x6x5/8 on the upper floors (2 to 7). Brace sizes are based on the maximum tension and compression forces experienced by each member at that floor. Typical braces span 16'-1" with the longest un-braced length equaling 22'-0" at the 5<sup>th</sup> floor. HSS members have a maximum dimension of 6" on one side so members can fit in a wall cavity without any disruptions to the architectural floor plans. (See Figure 8 below for 3-D model of the braced frame layout. Figure 9 shows the layout of each frame and the corresponding frame number.)

On the first floor, a W10x88 and HSS10x6x5/8 members are used as bracing elements (spanning 15'-6"). Large braces are needed to resist the large tension and compression forces experienced by the bracing elements on the first floor. To install braces in the first floor, minor modifications in the architectural floor plans must be completed to hide the braces in nearby wall cavities. If exposed bracing in the first floor is desired, an architectural study should be completed to determine the aesthetics of these spaces.

Comparing the base shears from the lateral loads, it is apparent that wind pressures control the design in the North-South direction ( $V = 1045k$ ), whereas seismic forces control the design in the East-West direction ( $V=979k$ ). When analyzing only wind forces, the design of braced frames in place of moment frames reduces the overall story drift from 3.41" (E-W) and 3.66" (N-S), with moment frames, to 1.45" (E-W) and 2.16" (N-S) with braced frames. A displacement of 2.16" corresponds to an H/555 value compared to the accepted value of H/400 for wind. Similarly, story drift between the 1<sup>st</sup> floor and 2<sup>nd</sup> floor is reduced to 0.19" (E-W) and 0.21" (N-S) using braced frames.

After analyzing the seismic forces, the maximum story displacements at the roof level are 4.69" (E-W) and 4.76" (N-S) assuming a torsional amplification factor ( $A_x$ ) equal to 1.0. Accidental Torsion ( $M_t$ ) and Torsional Amplification Factors ( $A_x$ ) are calculated in Table 5, shown below. The calculated values for  $A_x$  are less than 1.0; therefore, no amplification is required for the torsional moments.

Torsional Amplification Factor										
	Frame 1		Frame 8							
Level	Disp-X	Disp-Y	Disp-X	Disp-Y	$d_{ave}$ (x)	$d_{ave}$ (y)	$d_{max}$ (x)	$d_{max}$ (y)	$A_x$ (x)	$A_x$ (y)
8	4.69	4.63	4.69	4.76	4.69	4.69	4.69	4.76	0.70	0.73
7	4.05	4.02	4.06	4.24	4.06	4.13	4.06	4.24	0.70	0.73
6	3.35	3.33	3.35	3.50	3.35	3.42	3.35	3.50	0.69	0.73
5	2.22	2.15	2.22	2.24	2.22	2.20	2.22	2.24	0.69	0.72
4	1.55	1.44	1.53	1.48	1.54	1.46	1.55	1.48	0.70	0.71
3	0.91	0.81	0.88	0.81	0.90	0.81	0.91	0.81	0.72	0.69
2	0.44	0.33	0.42	0.31	0.43	0.32	0.44	0.33	0.73	0.74
1	0.00	0.00	0.00	0.00	0.00	0.00	0.00	0.00	0.00	0.00

Accidental Torsion						
Level	$L_x$ (E-W)	$L_y$ (N-S)	$e_x$	$e_y$	Force (k)	Mom (k-ft)
8	214	160	8	10.7	234	2503.80
7	214	160	8	10.7	224.6	2403.22
6	214	160	8	10.7	204.4	2187.08
5	214	160	8	10.7	160.8	1720.56
4	214	160	8	10.7	84	898.80
3	214	160	8	10.7	52.8	564.96
2	214	160	8	10.7	19.6	209.72
1	214	160	8	10.7	0	0.00

Table 5: Torsional Amplification Factors and Accidental Torsion

Section 12.8.6 of the ASCE 7-05 code defines “design story drift” ( $\delta_x$ ) as the difference in deflection at the center of mass between two adjacent stories. Deflections ( $\delta$ ) determined from an elastic analysis (RAM Frame) are multiplied by the equation:

$$\delta_x = (C_d * \delta) / I$$

to find the “design story drift” value. These values are then compared to the “allowable story drift” value ( $\Delta_a$ ) from Table 12.12-1 in ASCE 7-05. For the proposed braced frame structure, an

allowable story drift of 1.6” is calculated for a 13’-3” typical floor height. See Table 6 (below) for Story Drift calculations and comparisons to the allowable story drift set by code.

Story Drift Determination							
Level	Disp-x	Disp-y	C <sub>d</sub>	I	d <sub>x</sub> (x)	d <sub>x</sub> (y)	Δ <sub>allow</sub>
8	4.69	4.76	3.25	1.5	1.39	1.45	1.6
7	4.05	4.09	3.25	1.5	1.52	1.58	1.6
6	3.35	3.36	3.25	1.5	2.45	2.43	2.4
5	2.22	2.24	3.25	1.5	1.47	1.58	1.6
4	1.54	1.51	3.25	1.5	1.41	1.52	1.6
3	0.89	0.81	3.25	1.5	1.00	1.06	1.6
2	0.43	0.32	3.25	1.5	0.93	0.69	1.6
1	0	0	3.25	1.5	0.00	0.00	0

Table 6: Story Drift calculations for seismic loads

Notice that at Level 6, the calculated design story drift (2.45” and 2.43”) slightly exceeds the allowable story drift (2.4”) set by code. I assumed this was acceptable because the design story drifts are well within 5% of the acceptable drift. Also, additional stiffness can be found in the frames by taking advantage of the column base plate connections. The existing base plates were over-designed to handle some moment capacity. The moment capacity of the 2” base plates is calculated to be 432 kip-ft. Column bases that do not experience a moment greater than the base plate capacity can be found by analyzing the proposed braced frame design with fixed connections at the column base. These column bases can be assumed fixed in the final RAM analysis. Additional base plate moment capacity can be achieved with a slight increase in the base plate size; thus, more columns can be assumed fixed at the base.

Therefore, a small increase in the size of the base plate connections could save a significant amount of steel tonnage in the future. The added stiffness of moment connections at column bases will allow for reductions in column size as well as other lateral members in the building.

\* The design of foundations was not completed as part of this study. Note: designing base plates to handle moment forces will have an adverse effect on the foundations below the columns. Foundations below columns with fixed base connections will most likely require more rebar and concrete in their design. These are all factors that must be kept in mind when designing a complete structural system.

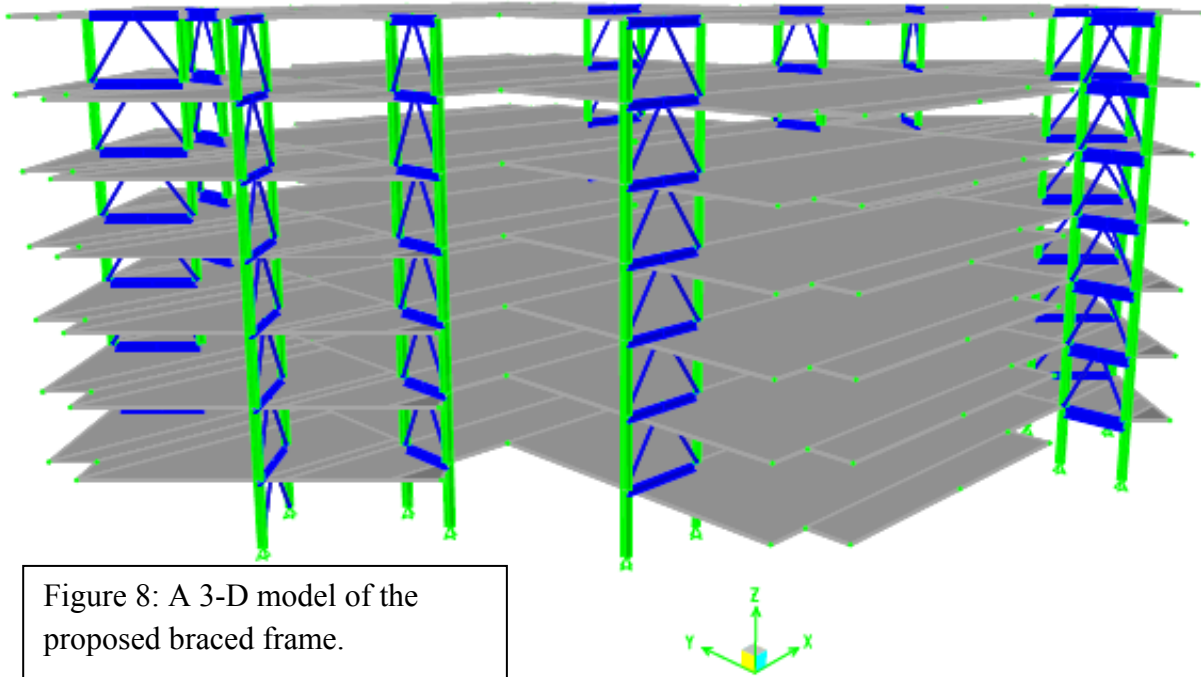

Figure 8: A 3-D model of the proposed braced frame.

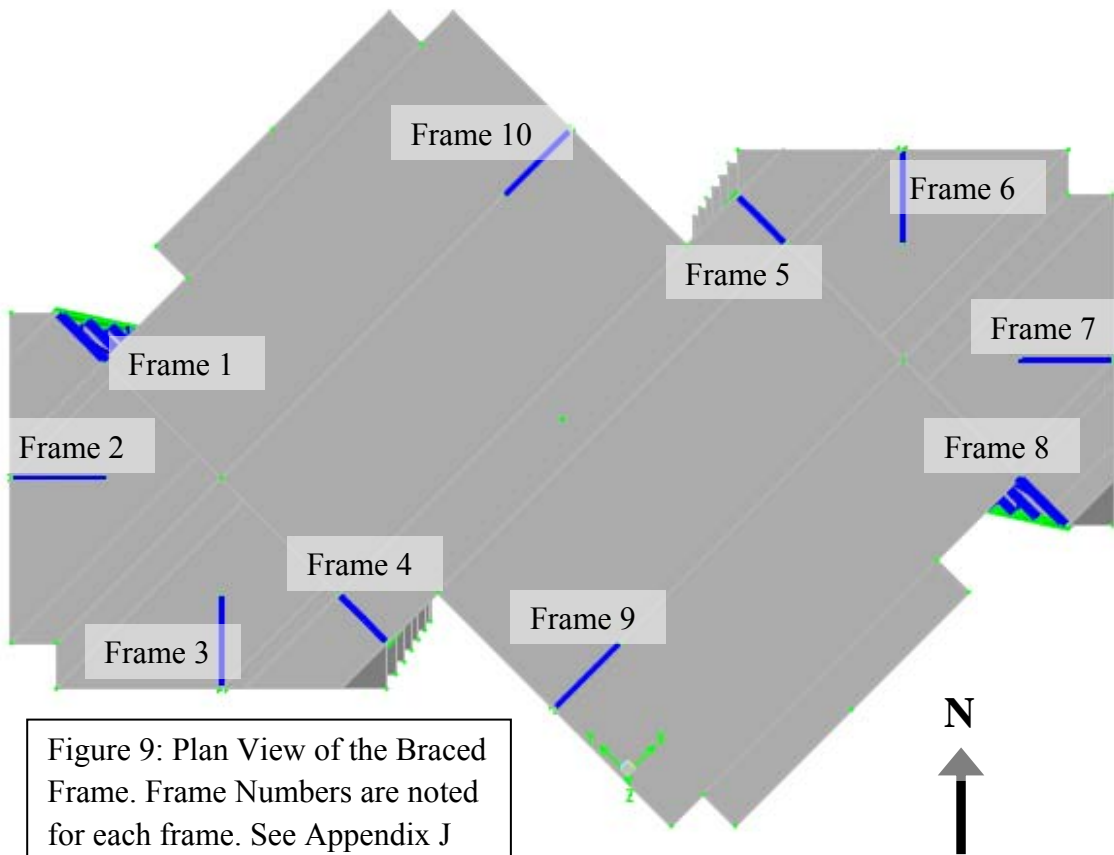

Figure 9: Plan View of the Braced Frame. Frame Numbers are noted for each frame. See Appendix J for framing details

## **BREADTH STUDY: CONSTRUCTION MANAGEMENT AND COST SAVINGS**

---

A change in the structural design of a project will have an immediate impact on the estimated cost and construction schedule of a building. Selection of a structural system is crucial for most projects because the construction of the structure falls on the critical path of any construction schedule. Any delay or extension of the critical path could end up costing an owner more money for additional construction time and lost income.

\* In this part of the report (Construction Breadth Study), the terms “moment frame system” and “braced frame system” refer to the entire steel structure used with that lateral system. The same gravity system (existing gravity system) is used in the comparison of the two lateral systems.

### ***COST ANALYSIS:***

A preliminary cost analysis was already discussed for the floor systems of Swedish American Hospital. Previously, on pages 20 through 22, castellated beams were proposed in lieu of the existing gravity framing layout. It was concluded that the use of castellated beams could indeed reduce the weight of the structure, but at a 39% increase in cost. Therefore, the existing gravity system is the most cost efficient steel framing system (See Appendix D for a copy of the R.S. Means sheet and rough cost estimate calculations).

The proposal of a braced framed system in place of a moment frame system has a significant impact on the cost of construction. A structural takeoff was completed for both the existing moment frames and the proposed braced frame systems (see Table 7 below). Charlie Carter, a professional engineer for AISC and Mentor for 5<sup>th</sup> year Penn State AE students, listed unit prices per pound of steel (\$/lb) in an email addressed to students. In the email, he is quote as staying, “I previously posted some cost data on wide-flange and HSS material costs (\$0.44 per pound for W-shapes; \$0.49 for HSS).” He also suggested using a 0.27 divisor factor which differs slightly from the factor cited below from Modern Steel Construction [MSC]. In the March 2008 issue of MSC, Charlie also published an article titled “Save More Money”. In this article he says,

“...it can be stated that the current distribution of cost... for a typical structural steel building is approximately as follows: Material Costs – 25%, Fabrication and Erection Labor Costs – 60%, Other Costs – 15%.”

The table below multiplies the total weight of steel of the framing system by the corresponding unit price. This material cost is then divided by the “divisor factor” to find the total steel cost (including material, fabrication and labor, and other costs).

<b>Project Cost Comparison</b>						
<b>Moment Frames</b>						
Item	Pieces	Weight (Tons)	Cost/lb	Mat'l Cost	Divisor Factor	Steel Cost
Gravity Beams	925	309.6	0.44	\$272,448	0.27	\$1,009,067
Lateral Beams	210	444.5	0.44	\$391,160	0.27	\$1,448,741
Gravity Columns	42	47.7	0.44	\$41,976	0.27	\$155,467
Lateral Columns	120	349.5	0.44	\$307,560	0.27	\$1,139,111
Total Mat'l Cost				\$1,013,144	Total Steel Cost	\$3,752,385

Total Pieces	Pieces/Day	Number of Days
1297	35	38

<b>Braced Frames</b>						
Item	Pieces	Weight (Tons)	Cost/lb	Mat'l Cost	Divisor Factor	Steel Cost
Gravity Beams	1065	418.1	0.44	\$367,928	0.27	\$1,362,696
Lateral Beams	70	22.8	0.44	\$20,064	0.27	\$74,311
Gravity Columns	102	102.1	0.44	\$89,848	0.27	\$332,770
Lateral Columns	60	142.4	0.44	\$125,312	0.27	\$464,119
Lateral Braces	108	29.9	0.49	\$29,302	0.27	\$108,526
Total Mat'l Cost				\$632,454	Total Steel Cost	\$2,342,422

Total Pieces	Pieces/Day	Number of Days
1405	70	21

Table 7: Total Steel Cost Estimate and Days for Steel Erection

Although the moment frame system has fewer members, the total weight of the members is greater than the total weight of the braced frame members. The lighter brace frame system has an estimated total steel cost of \$2,342,400 compared to the estimated total steel cost of \$3,752,400 for the existing structural system, a savings of approximately 37% or \$1,409,963.

**CONSTRUCTION SCHEDULE:**

Not only does the switch to braced frames potentially save money in steel costs, it can also reduce the number of days needed for steel erection. Andy Pilipczuk and John Weaver, both from Turner Construction, were very helpful in assisting with this construction study. In a discussion with Mr. Weaver, he stated that 70 – 80 is a typical average for number of pieces of steel erected per day. For the Swedish American Hospital, he said they were only able to erect approximately 35 pieces of steel per day due to the fairly large and detailed flange bolted moment connections needed for the lateral frames.



Table 7 (above) lists the total number of steel members for each system and the corresponding average number of steel members erected per day. Dividing the total number of members by the “framing rate” will give the total number of days to erect each steel structure. Assuming the lower bound of 70 pieces of steel/day for the braced frames, a total of 21 days is needed to erect the proposed braced frame steel structure. Similarly, a total of 38 days is needed to erect the existing steel structure with moment frames.

The number of days calculated above is just a rough calculation for steel erection time. It considers only the wide flange and HSS framing members, neglecting installation of steel decking, shear studs, periodic welding and other activities. For a more accurate schedule comparison, further analysis is required.

A mobile Manitowoc Model 777 crane was used to erect the existing structure. Mr. Weaver said a “crane way” was created along the south side of the structure with compacted gravel. The moment framed structure was then erected with the crane moving west to east, away from the already constructed buildings. The construction schedule submitted by Turner is a Critical Path Method (CPM) schedule and shows each floor is divided into 3 phases. The schedule then shows the structure erected floor by floor with some overlap between floors. (See Appendix K for the existing construction schedule of the moment frame system)

The proposed braced frame system is broken into three framing phases (Phase 1, 2 and 3). These phases are divided into the west, central, and east framing sections. Figure 10 (below) outlines these 3 phases on a typical framing plan. A “crane way” will still be created so the crane can work its way around the building, but each phase of the structure will be erected from one stationary point. This results in a total of 3 points from which to erect the entire structure and should limit the number of times the crane is required to move during construction. From the 3 crane placements, the longest pick is approximately 130’ and the heaviest pick will be approximately 6500lbs. From the Manitowoc website ([www.manitowoccranegroup.com](http://www.manitowoccranegroup.com)) a Manitowoc Model 555 crane can be used for the steel erection of the braced frame system. Using a smaller crane model can also be a source of cost savings. Appendix M contains the “Heavy Lift Load Charts” for the Manitowoc 555. (See Figure 11 below for the proposed erection plan).

Unlike the existing schedule, each phase of the proposed schedule will be erected independently of one another, with no overlap. In other words, Phase 2 will be erected once Phase 1 is complete, and Phase 3 will be erected once Phase 2 is complete. By code, a structure cannot have more than two open stories during construction. Therefore, in each phase where more than 2 stories exist, after the first two stories are erected, metal decking will be installed before construction continues on the upper stories. By installing metal decking two floors at a time, it limits the number of changes from rolled steel to metal decking and vice versa, potentially saving time and money. After all of the steel erection is complete, concrete can be poured on the metal decking to form the floor slabs. Separating these two tasks should help minimize any conflicts between the two trades. (See Appendix L for a CPM schedule of proposed braced frame system)

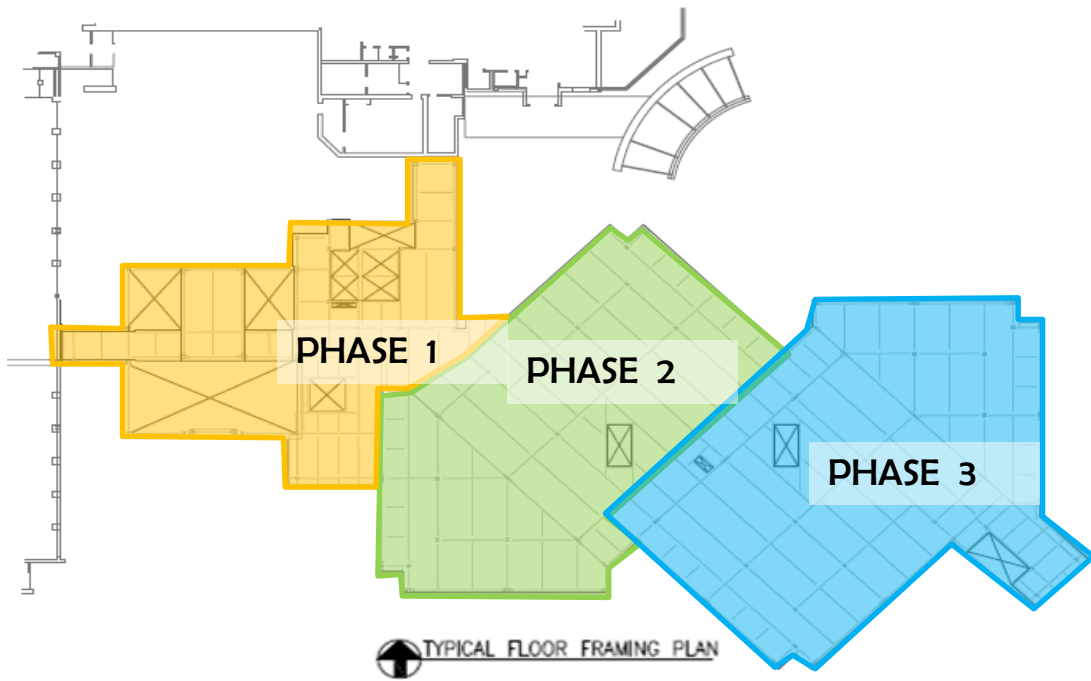

Figure 10: Steel Framing Phasing Plan

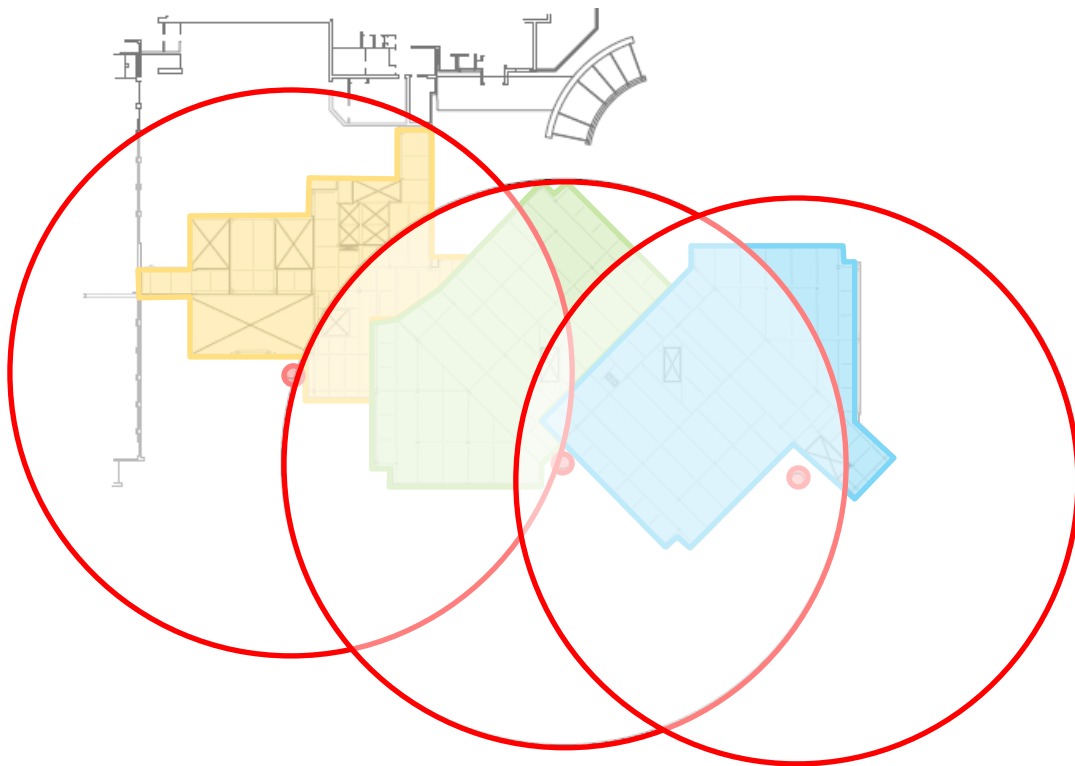

Figure 11: Steel Erection Plan

***CONCLUSION:***

Overall, the switch from a moment frame system to a braced frame system has many positive impacts on the construction of the building. Although a braced frame system adds extra members to the structure, it has potential to be significantly cheaper because of the reduced weight of steel. It can also be erected quicker based on the number of steel pieces erected per day (provided by Turner Construction). From the existing construction schedule (Appendix K), the finish date for the steel structure is 29 July 2005. For the proposed construction schedule with braced frames (Appendix L), a finish date of 7 July 2005 is expected. This is a difference of 16 schedule days (weekdays). Therefore, the total length of the project can potentially be shortened by two weeks since a building's structure is always on the critical path of a construction schedule. Money can also be saved by using a smaller crane, the Manitowoc 555; which is one model smaller than the crane used on the existing project.

Philip Frederick  
Structural Option  
Advisor: Dr. Andres Lepage  
April 9<sup>th</sup>, 2008

Swedish American Hospital  
Heart and Vascular Center  
1400 Charles St, Rockford, IL

## **BREADTH STUDY: FAÇADE – WINDOW CONDENSATION ANALYSIS**

---

\*DUE TO ITS SENSITIVE NATURE, THIS TOPIC WILL BE DISCUSSED ONLY BETWEEN THE STUDENT AND THE AE FACULTY AND WILL NOT BE PRESENTED TO THE PUBLIC.

THIS THEORETICAL STUDY IS FOR EDUCATIONAL PURPOSES ONLY AND ANY CONCLUSIONS DEVELOPED HEREIN SHALL NOT BE TAKEN AS FACT.

Philip Frederick  
Structural Option  
Advisor: Dr. Andres Lepage  
April 9<sup>th</sup>, 2008

Swedish American Hospital  
Heart and Vascular Center  
1400 Charles St, Rockford, IL

# APPENDIX

## APPENDIX A

Alternative gravity framing plans for the floor section.

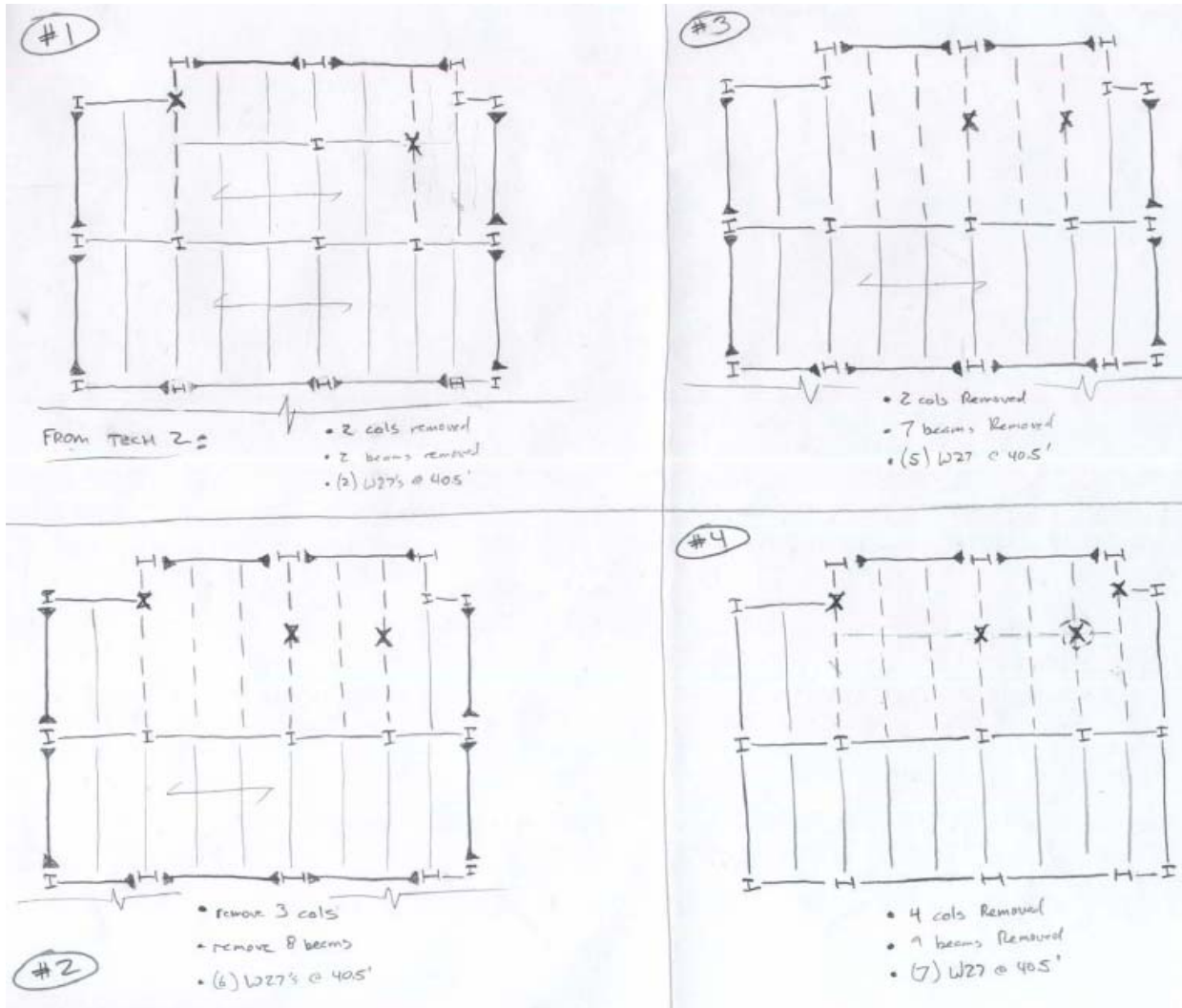

Alternative gravity framing plans for the wing section.

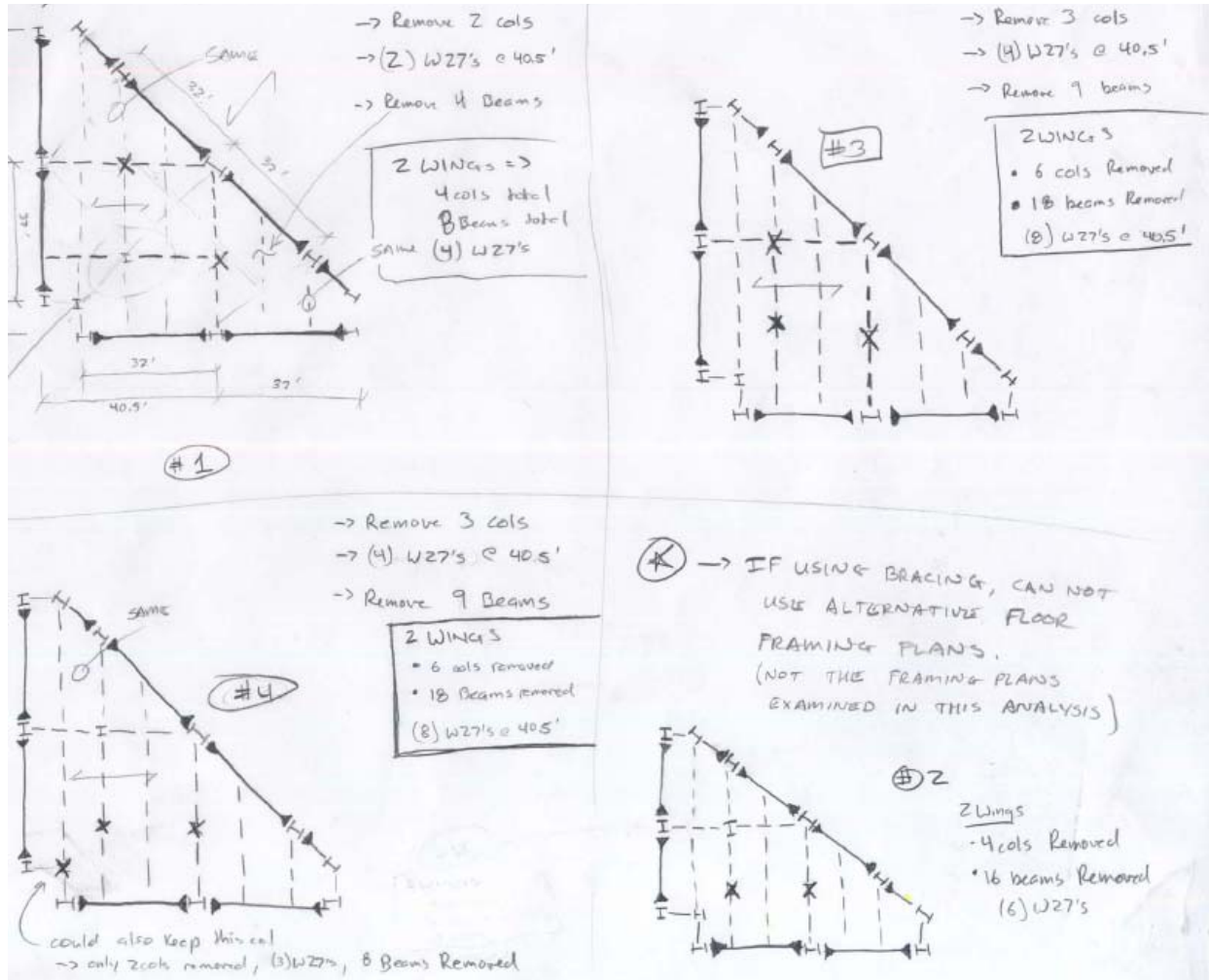

**APPENDIX B**

Composite Castelled Beam Design Spreadsheet (calculations shown for typical gravity beam)

SmartBeam™

CASTELLATED BEAM INFORMATION		LOADING INFORMATION				EXPAND'D. SXN. PROP'S	
Job Name	Swedish American Hospital	Uniform Distributed Loads			Avg. wt.		40.5 plf
Beam Mark #	CB - Beam	Live Load	1036 plf	Pre-comp %	Anet		8.753 in <sup>2</sup>
Span	40.500 ft	Dead Load	831 plf	Pre-comp %	Agross		14.955 in <sup>2</sup>
Spac. Left	10.600 ft	Concentrated Point Loads			lx net		1406.79 in <sup>4</sup>
Spac. Right	10.600 ft	Load #	Magnitude	Dist from	lx gross		1594.82 in <sup>4</sup>
Mat. Strength-Fy	50 ksi	(#)	(kips)	(%)	Sx net		90.75 in <sup>3</sup>
Round Duct Diam.	15.273 in	P1	0.00	0%	Sx gross		107.02 in <sup>3</sup>
Duct W x H	8.800 in	P2	0.00	0%	rx min		10.33 in
Castellated Beam	CB27X35/46	P3	0.00	0%	ly		18.90 in <sup>4</sup>
Root Beams (T/B)	W18X35	P4	0.00	0%	Sy		6.30 in <sup>3</sup>
d	17.7	COMPOSITE INFORMATION			COMPOSITE SXN. PROP'S		
bf	6.06	Concrete & Deck:		Shear Studs:	n		11.76
tf	0.425	conc. strength - fc' (psi)	4000	stud dia. (in)	3/4"	beflec.	121.50 in
tw	0.3	conc. wt. - wc (pcf)	115	stud ht. (in)	5 3/4	Actr	33.584 in <sup>2</sup>
CASTELLATION PARAMETERS:		conc. above deck - tc (in)	3 1/4	studs per rib	1	N.A. ht.	28.23 in Deck
NonStandard e	7.100 in	rib height - hr (in)	3	composite %	100%	ltr	4288.71 in <sup>4</sup>
Beam-Label b	5.750 in	rib width - wr (in)	6	Stud Spacing:		leffec.	4288.71 in <sup>3</sup>
NS on Plans dt	4.250 in			N=40 Uniformly Dist.		Sxconc	811.92 in <sup>3</sup>
S	25.700 in	RESULTS		WARNINGS		Sxsteel	151.93 in <sup>3</sup>
dg	27.260 in	Failure Mode	Interaction	Status	CONSTRUCTION BRIDGING		
phi	58.485 deg	Bending	0.936	<= 1.0 OK!!	End Connection type	Double clip	
ho	18.760 in	Web Post	0.998	<= 1.0 OK!!	Min. No. Of Bridging Rows	1	
wo	18.600 in	Shear	0.985	<= 1.0 OK!!	Max. Bridging Spacing (ft)	37	
		Concrete	0.273	<= 1.0 OK!!			
		Pre-Comp.	0.694	<= 1.0 OK!!			
		Overall	0.998	<= 1.0 OK!!			
		Pre-Composite Deflec.	1.078"	=L/451			
		Live Load Deflection	0.504"	=L/964			



3/24/2008



**APPENDIX C**

Hand calculations comparing existing floor framing weight with proposed castellated beam framing weight.

ALT FLOOR # 4: BEAMS ONLY

TYP/FUTURE = (12) 24x55, (2) 21x50  
 MECH = (12) 24x55, (2) 21x50  
 ROOF = (12) 24x55, (2) 21x50

REG:  $(7)(12)(55)(40.5) = 187110$   
 $+ (7)(2)(50)(40.5) = 28350$   
215460<sup>lbs</sup>

CAST BEAMS: BEAMS ONLY (405)

TYP/FUTURE = (14) CB 27 x 35/46  
 MECH = (14) CB 36 x 62  
 ROOF = (14) CB 24 x 31

NEW:  $(5)(14)(40.5)(40.5) = 114317$   
 $+ (1)(14)(62)(40.5) = 35154$   
 $+ (1)(14)(31)(40.5) = 17577$   
167548

ALT FLOOR:  
 W = 615958

ORIGINAL FLOOR:  
 W = 565174

$615958^{lb} - 215460^{lb} + 167548^{lb}$   
 $= 568046 \geq 565174$

NO GOOD

NEED CAST. BEAMS  
 $\leq 59 \text{ pif}$

OR

REPLACE HEAVIER  
 CAVITY FRAMING MEMBERS  
 (GIRDERS) W/ CASTELLATED  
BEAMS

ALT #4 w/ SELECT BEAMS/GIRDERS AS CASTELLATED BEAMS

EXISTING ALT #4: TYP FLOOR - (12) 24x55 x 40.5' x 5 stays = 133650  
 (2) 21x50 x 40.5 x 5 = 20250  
 (2) 21x44 x 22.6' x 5 = 9944  
 (2) 24x68 x 32' x 5 = 21760

MECH - (12) 24x55 x 40.5' = 26730  
 (2) 21x50 x 40.5' = 4050  
 (2) 30x99 x 32' = 6336  
 (2) 24x62 x 22.6' = 2802

ROOF - (12) 24x55 x 40.5 = 26730  
 (2) 21x50 x 40.5 = 4050  
 (2) 18x40 x 22.6 = 1808  
 (2) 24x68 x 32' = 4352

262462<sup>16</sup>

CAST BEAM REPLACEMENTS

TYP FLOOR - (14) CB 27 x 35/46 x 40.5' x 5 stays = 114817  
 (2) CB 27 x 40 x 22.6' x 5 = 9040  
 (2) CB 30 x 59/57 x 32' x 5 = 17120

MECH - (14) CB 36 x 62 x 40.5' = 35154  
 (2) CB 30 x 50 x 22.6' = 2260  
 (2) CB 30 x 93 x 32' = 5962

ROOF - (14) CB 24 x 31 x 40.5' = 17577  
 (2) CB 30 x 40 x 32' = 2560  
 (2) CB 24 x 31 x 22.6' = 1401

205881

ALT FLOOR #4

W = 615958<sup>15</sup>

ORIGINAL FLOOR

W = 565174<sup>15</sup>

615958 - 262462 + 205881 = 559,377<sup>15</sup> ≤ 565174<sup>15</sup>

✓OK

**APPENDIX D**

R.S. Means Structural Steel Framing Cost Sheet.

<b>05 12 Structural Steel Framing</b>											
<b>05 12 23 – Structural Steel for Buildings</b>											
<b>05 12 23.77 Structural Steel Projects</b>											
	Crew	Daily Output	Labor Hours	Unit	Material	2008 Bare Costs Labor	2008 Bare Costs Equipment	Total	Total Ind O&P		
3000		Maximum	E-6	5.50	23.273	Ton	3,300	985	340	4,625	5,725
3040		Safety steel, minimum		2.50	51.200		3,200	2,175	745	6,120	8,150
3070		Maximum	▼	1.50	85.333		4,225	3,625	1,250	9,100	12,400
3100		Roof trusses, minimum	E-5	13	6.154		3,075	261	131	3,467	4,000
3200		Maximum		8.30	9.639		3,750	410	205	4,365	5,075
3210		Schools, minimum		14.50	5.517		2,200	234	117	2,551	2,975
3220		Maximum	▼	8.30	9.639		3,200	410	205	3,815	4,475
3400		Welded construction, simple commercial bldgs., 1 to 2 stories	E-7	7.60	10.526		2,250	445	241	2,936	3,525
3500		7 to 15 stories	E-9	8.30	15.422		2,600	655	268	3,523	4,300
3700		Welded rigid frame, 1 story, minimum	E-7	15.60	5.063		2,300	215	116	2,631	3,025
3800		Maximum	**	5.50	14.545	▼	2,975	615	335	3,925	4,725
3810		Fabrication shop costs (included in project material cost, above)									
3820		Mini mill base price, A992				Ton	725			725	800
3830		Mill extra for delivery to shop					220			220	242
3840		Shop extra for shop drawings and detailing					240			240	264
3850		Shop fabricating and handling					800			800	880
3860		Shop sandblasting and primer coat of paint					125			125	138
3870		Shop delivery to the job site					90			90	99
3880		Total material cost, shop fabricated, primed, delivered				▼	2,200			2,200	2,425
3900		High strength steel mill spec extras: A242, A441,									
3950		A529, A572 (42 ksi) and A992: same as A36 steel				Ton	100			100	110
4000		Add to A992 price for A572 (50, 60, 65 ksi)				"	92.50			92.50	102
4100		A588 Weathering									
4200		Mill size extras for W-Shapes: 0 to 30 pft: no extra charge									
4210		Member sizes 31 to 65 pft, add				Ton	.10			.10	.11
4220		Member sizes 66 to 100 pft, add					.10			.10	.11
4230		Member sizes 101 to 387 pft, add				▼	56			56	61.50
4300		Column base plates, light, up to 150 lb	2 Swwk	2000	.008	Lb.	1.21	.34		1.55	1.95
4400		Heavy over 150 lb	E-2	7500	.007	"	1.27	.31	.21	1.79	2.16
4600		Castellated beams, light sections, to 50# /L.F., minimum		10.70	5.234	Ton	2,300	219	146	2,665	3,100
4700		Maximum		7	8		2,525	335	224	3,084	3,600
4900		Heavy sections, over 50# per L.F., minimum		11.70	4.786		2,425	200	134	2,759	3,150
5000		Maximum	▼	7.80	7.179		2,650	300	201	3,151	3,650
5390		For projects 75 to 99 tons, add					10%				
5392		50 to 74 tons, add					20%				
5394		25 to 49 tons, add					30%	10%			
5396		10 to 24 tons, add					50%	25%			
5398		2 to 9 tons, add					75%	50%			
5399		Less than 2 tons, add				▼	100%	100%			
<b>05 12 23.80 Subpurlins</b>											
0010	<b>SUBPURLINS</b> R051223-50										
0020	Bull tees, shop fabricated, pointed, 32-5/8" O.C., 40 pft L.L.										
0100		Type 178, max 8'-9" span, 2.15 pft, 2" high x 1-5/8" wide	E-1	4200	.006	S.F.	1.53	.24	.03	1.80	2.12
0200		Type 218, max 10'-2" span, 3.19 pft, 2-1/8" high x 2-1/8" wide	"	3100	.008		1.77	.32	.04	2.13	2.54
1420		For 24-5/8" spacing, add					33%	33%			
1430		For 48-5/8" spacing, deduct				▼	50%	50%			

Hand calculations of Castellated Beam cost estimate compared to existing framing estimate

### CASTELLATED BEAM COST ESTIMATE

- From R.S MEANS, TAKE AVERAGE OF LIGHT SECTIONS
- " " HEAVY SECTIONS

$$\text{LIGHT} = \frac{2665 + 3084}{2} = \$2874.5/\text{TON}$$

$$\text{HEAVY} = \frac{2759 + 3151}{2} = \$2955/\text{TON}$$

FOR LIGHT SECTIONS ( ≤ 50 PLF ) :

$$162.5^T \times 2875.5 = \$467,150$$

FOR HEAVY SECTIONS ( > 50 PLF ) :

$$43.4^T \times 2955 = \$128,146$$

$$\boxed{\text{TOTAL} = \$595,296}$$

WIDE FLANGE COSTS :

⊗ Assume \$0.44/lb

$$\$0.44 \times 262962^{lb} = \$115,483$$

(MAT'L COST)

Total weight of WF's replaced by CB's

⊗ Assume MAT'L = 27% of TOTAL STEEL COST

$$\frac{\$115,483}{0.27} = \boxed{\$427,715 \text{ TOTAL}}$$

## APPENDIX E

Preliminary SAP analysis of typical braced frame showing the axial forces in each member.

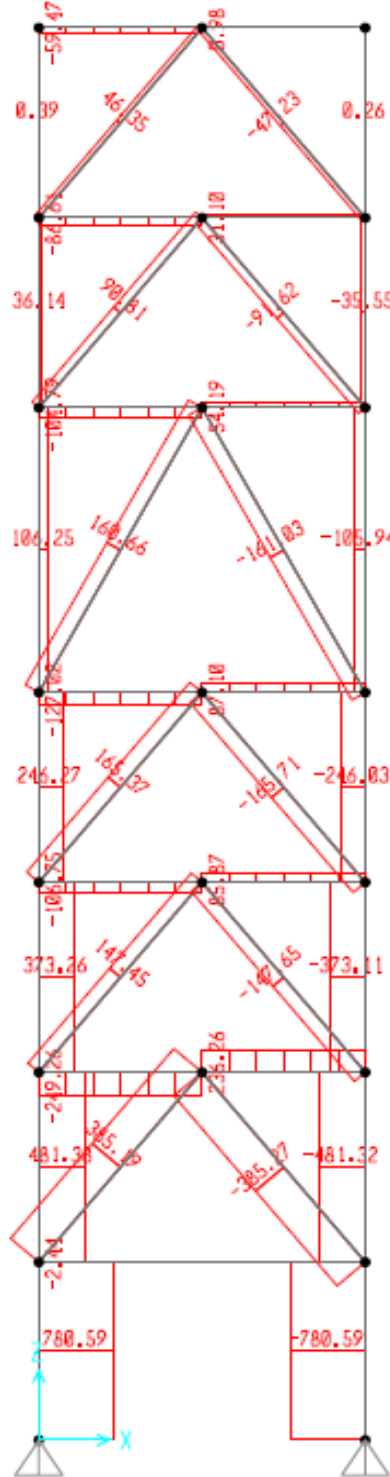

**APPENDIX F**

Braced Frame - Pinned Bases								
Frame 1/8								
Column	Member	Length	Story	LC	Max P (k)	Max M (k-ft)	Max V (k)	Peff
Column	W14x120	13.33	7	2	49.1	0.8	0.0	50
				4	44.1	4.8	0.4	52
Column	W14x120	13.33	7	2	20.3	0.8	0.0	22
				4	18.3	4.8	0.4	27
Column	W14x120	13.33	6	5	35.6	12.6	0.6	57
				6	84.8	8.4	0.7	99
Column	W14x120	13.33	6	5	107.8	12.6	0.7	129
Column	W14x120	20	5	5	27.3	16.3	1.4	55
				6	149.5	8.4	0.6	164
Column	W14x120	20	5	5	188.3	16.2	1.4	216
Column	W14x120	13.33	4	5	338.0	16.2	1.4	366
Column	W14x120	13.33	4	5	1.0	16.3	1.4	29
				6	246.6	4.5	0.0	254
Column	W14x120	13.33	3	5	447.7	18.0	1.5	479
Column	W14x120	13.33	3	5	38.0	19.0	1.6	71
				6	338.8	4.0	0.0	346
Column	W14x120	13.33	2	4	52.3	25.7	2.0	96
				5	577.0	18.0	0.3	608
Column	W14x120	13.33	2	4	434.0	29.6	2.4	485
Column	W14x120	12.5	1	5	722.6	86.2	7.4	870
Column	W14x120	12.5	1	4	553.9	67.1	5.8	669
				5	-173.0	82.5	7.1	-32
					Max P	Max M	Max V	Max Peff
					722.6	86.2	7.4	870
@ 13.3'	ØXn				1390.0	795.0		1390.0

Beam	Member	Length	Story	LC	Max M (k-ft)	Max V (k)
Beam	W10x12	13.25	8	2	1.9	1.5
Beam	W10x12	13.25	7	2	3.4	2.6
Beam	W10x12	13.25	6	2	4.5	2.7
Beam	W10x12	13.25	5	2	6.3	33.0
Beam	W10x12	13.25	4	2	5.2	2.8
Beam	W10x12	13.25	3	2	5.7	2.9
Beam	W21x68	13.25	2	5	94.9	18.5
					Max M	Max V
					94.9	33.0
W10x12	ØMr				46.9	56.3
W21x68	ØMr				600.0	273

Brace	Member	Length	Story	LC	(Comp) Max P+ (k)	LC	(Tens) Max P (k)
1	HSS6x6x3/8	14.9	7	6	47.9	9	12.5
2	HSS6x6x3/8	14.9	7	9	14.1	6	-45.3
1	HSS6x6x3/8	14.9	6	6	51.6	9	-33.6
2	HSS6x6x3/8	14.9	6	9	35.2	6	-47.7
1	HSS6x6x3/8	21	5	6	67.7	5	-62.6
2	HSS6x6x3/8	21	5	5	66.5	6	-63.8
1	HSS6x6x3/8	14.9	4	4	85.8	5	-62.0
2	HSS6x6x3/8	14.9	4	5	67.9	4	-79.9
1	HSS6x6x3/8	14.9	3	4	96.7	5	-87.0
2	HSS6x6x3/8	14.9	3	5	91.3	4	-92.4
1	HSS6x6x3/8	14.9	2	4	105.7	5	-87.1
2	HSS6x6x3/8	14.9	2	5	91.5	4	-101.2
					Max Comp	Max Ten	-101.2
for HSS6x6x3/8			@15'	ØPn =	206.0	ØPn =	-248.0
for HSS6x6x3/8			@21'	ØPn =	138.0	ØPn =	-248.0

Braced Frame - Pinned Bases								
Frame 2								
Column	Member	Length	Story	LC	Max P (k)	Max M (k-ft)	Max V (k)	Peff
Column	W14x120	13.33	7	2	28.8	0.1	0	29
				5	26.4	7.7	0.6	40
Column	W14x120	13.33	7	2	46.5	0.05	0	47
				5	41.7	7.7	0.6	55
Column	W14x120	13.33	6	2	98.2	0.1	0	98
				5	47.8	11.3	0.3	67
Column	W14x120	13.33	6	5	137.2	11.3	0.3	157
Column	W14x120	20	5	2	167.3	0.1	0	167
				5	23.5	18	1.5	54
Column	W14x120	20	5	5	275.7	18.3	1.5	307
Column	W14x120	13.33	4	2	268.2	0.9	0.1	270
				3	-84	18	1.9	-53
Column	W14x120	13.33	4	5	553	18.3	2	584
Column	W14x120	13.33	3	2	355.2	3.2	0.3	361
				5	-186.6	31.4	3	-133
Column	W14x120	13.33	3	5	795.1	35.2	3.3	855
Column	W14x120	13.33	2	2	411.2	13.3	1.3	434
				5	-282.1	31.4	1.8	-228
Column	W14x120	13.33	2	5	997.3	35.1	3.6	1057
Column	W14x120	12.5	1	2	458.6	12.5	1.1	480
				5	-450.7	142.9	12.3	-206
Column	W14x120	12.5	1	5	1260.1	126.4	10.9	1477
					Max P	Max M	Max V	Max Peff
					1260.1	142.9	12.3	1477
W14x120	@ 13.3'	ØXn			1390.0	795.0		1390.0
W14x120	@12.5	ØXn			1415		+/-5%	1415
W14x132	@12.5	ØXn			1555			1555

Beam	Member	Length	Story	LC	Max M (k-ft)	Max V (k)
Beam	W16x26	18	8	2	2.34	39.6
Beam	W16x31	18	7	2	5.9	60.1
Beam	W16x31	18	6	2	13.5	60.9
Beam	W18x35	18	5	2	18.6	97.1
Beam	W16x31	18	4	2	14.2	61
Beam	W16x31	18	3	2	20	61.7
Beam	W21x68	18	2	5	154.9	72.2
					Max M	Max V
					154.9	97.1
W16x31	ØMr				203.0	131
W21x68	ØMr				600.0	273

Brace	Member	Length	Story	LC	(Comp) Max P+ (k)	LC	(Tens) Max P (k)
1	HSS6x6x3/8	16	7	2	39.9	9	-28.9
2	HSS6x6x3/8	16	7	9	55	-	-
1	HSS6x6x3/8	16	6	2	57.7	9	-84
2	HSS6x6x3/8	16	6	5	118.4	-	-
1	HSS8x6x5/8	22	5	2	55.4	9	-185.1
2	HSS8x6x5/8	22	5	5	220	8	-0.5
1	HSS8x6x1/2	16	4	2	77	9	-191.6
2	HSS8x6x1/2	16	4	5	240	-	-
1	HSS6x6x3/8	16	3	2	48.6	9	-162.2
2	HSS6x6x3/8	16	3	5	201.3	-	-
1	HSS8x6x1/2	16	2	2	47.7	9	-222.1
2	HSS8x6x1/2	16	2	5	264.2	-	-
1	W10x88	15.5	1	2	53.7	9	-698.4
2	W10x88	15.5	1	5	756.9	-	-
					Max Comp	Max Ten	-222.1
	for HSS6x6x3/8	@16'	ØPn =	195	ØPn =	-248	
	for HSS6x6x1/2	@16'	ØPn =	244	ØPn =	-318	
	for HSS8x6x1/2	@16'	ØPn =	303	ØPn =	-378	
	for HSS8x6x5/8	@22'	ØPn =	234.0	ØPn =	-457.0	
	for W10x88	@15.5'	ØPn =	808	ØPn =	-946	

Braced Frame - Pinned Bases								
Frame 3/6								
Column	Member	Length	Story	LC	Max P (k)	Max M (k-ft)	Max V (k)	Peff
Column	W14x120	13.33	7	2	39.5	0.1	0	40
				4	35.9	7.8	0.6	49
Column	W14x120	13.33	7	2	51.8	0.1	0	52
				4	46.5	7.8	0.6	60
Column	W14x120	13.33	6	2	111.6	0.9	0.1	113
				5	92	8.4	0.73	106
Column	W14x120	13.33	6	6	142.7	8.5	0.7	157
Column	W14x120	20	5	2	176.2	0.9	0.1	178
				4	93	8.4	0.6	107
Column	W14x120	20	5	6	241.4	8.5	0.6	256
Column	W14x120	13.33	4	2	291.4	0.9	0.1	293
				5	242.9	5	0.2	251
Column	W14x120	13.33	4	6	460.2	4.7	0.1	468
Column	W14x120	13.33	3	2	361	3.1	0.2	366
				10	-177	10.7	0.7	-159
Column	W14x120	13.33	3	6	621.6	13.5	0.8	645
Column	W14x120	13.33	2	2	416.1	11.9	1.2	437
				4	-81	40.4	3	-12
Column	W14x120	13.33	2	6	796.2	18.4	0.4	828
				8	605	24.8	1.5	648
Column	W14x120	12.5	1	2	461.3	12.4	1.1	483
				4	-206	95	8.2	-43
Column	W14x120	12.5	1	4	991.3	79.5	6.8	1128
					Max P	Max M	Max V	Max Peff
					991.3	95.0	8.2	1128
@ 13.3'	ØXn				1390.0	795.0		1390.0

Beam	Member	Length	Story	LC	Max M (k-ft)	Max V (k)
Beam	W12x19	18	8	2	15.2	8.8
Beam	W12x19	18	7	2	25.6	14.4
Beam	W12x19	18	6	2	28.3	14.7
Beam	W12x19	18	5	2	40.2	21.8
Beam	W12x19	18	4	2	29.2	14.8
Beam	W12x19	18	3	2	30.2	14.9
Beam	W21x68	18	2	2	138.5	33.1
					Max M	Max V
					138.5	33.1
W12x19	ØMr				92.6	85.7
W21x68	ØMr				600.0	273

Brace	Member	Length	Story	LC	(Comp) Max P+ (k)	LC	(Tens) Max P (k)
1	HSS8x6x3/8	16	7	2	24.8	10	-41.5
2	HSS8x6x3/8	16	7	10	52.8	2	-3.6
1	HSS8x6x3/8	16	6	2	31.2	10	-49.2
2	HSS8x6x3/8	16	6	10	60.5	-	-
1	HSS8x6x3/8	22	5	5	41.8	10	-129.3
2	HSS8x6x3/8	22	5	6	141	5	-16.3
1	HSS8x6x3/8	16	4	2	38.1	8	-119.5
2	HSS8x6x3/8	16	4	4	138.8	-	-
1	HSS8x6x3/8	16	3	2	25.3	8	-156.7
2	HSS8x6x3/8	16	3	4	173.1	-	-
1	HSS8x6x3/8	16	2	2	22.8	8	-177.3
2	HSS8x6x3/8	16	2	4	195.1	-	-
1	HSS10x6x5/8	15.5	1	2	31.1	8	-400.2
2	HSS10x6x5/8	15.5	1	4	434.7	-	-
					Max Comp	Max Ten	-400.2
HSS8x6x3/8	@ 16'	ØPn =			239.0	ØPn =	-293.0
HSS8x6x5/8	@ 22'	ØPn =			234.0	ØPn =	-457.0
HSS10x6x5/8	@ 15.5'	ØPn =			443	ØPn =	-535



Braced Frame - Pinned Bases								
Frame 4/5								
Column	Member	Length	Story	LC	Max P (k)	Max M (k-ft)	Max V (k)	Peff
Column	W14x120	13.33	7	2	11.5	0.1	0	12
				4	10.5	4.8	0.4	19
Column	W14x120	13.33	7	2	65.83	0.1	0	66
				4	59	4.8	0.4	67
Column	W14x120	13.33	6	5	93	12.6	0.7	115
Column	W14x120	13.33	6	5	69.6	12.6	0.6	91
				6	118.8	8.4	0.7	133
Column	W14x120	20	5	5	191	16.1	1.4	219
Column	W14x120	20	5	5	59.2	16.2	1.4	87
				6	181.3	8.5	0.6	196
Column	W14x120	13.33	4	5	316.4	16.3	1.4	344
Column	W14x120	13.33	4	5	78.2	16.2	1.4	106
				6	323.9	4.4	0.1	331
Column	W14x120	13.33	3	5	425.9	15.8	1.3	453
Column	W14x120	13.33	3	5	52	18	1.6	83
				6	428.5	4.8	0.1	437
Column	W14x120	13.33	2	5	545.8	22.5	1.6	584
Column	W14x120	13.33	2	6	543.2	23.9	1.5	584
Column	W14x120	12.5	1	5	674.9	94.4	8.1	837
Column	W14x120	12.5	1	4	693	63.3	5.5	802
					Max P	Max M	Max V	Max Peff
					693.0	94.4	8.1	837
@ 13.3'	ØXn				1390.0	795.0		1390.0

Beam	Member	Length	Story	LC	Max M (k-ft)	Max V (k)
Beam	W10x12	13.25	8	2	4	3.2
Beam	W10x12	13.25	7	2	6.9	5.3
Beam	W10x12	13.25	6	2	8.2	5.5
Beam	W10x12	13.25	5	2	11.3	8.1
Beam	W10x12	13.25	4	2	9	5.6
Beam	W10x12	13.25	3	2	9.6	5.7
Beam	W21x68	13.25	2	5	112.3	24
					Max M	Max V
					112.3	24.0
W10x12	ØMr				46.9	56.3
W21x68	ØMr				600.0	273

Brace	Member	Length	Story	LC	(Comp) Max P+ (k)	LC	(Tens) Max P (k)
1	HSS6x6x3/8	14.9	7	-	-	5	-70.4
2	HSS6x6x3/8	14.9	7	5	76.4	-	-
1	HSS6x6x3/8	14.9	6	8	11.8	5	-87.7
2	HSS6x6x3/8	14.9	6	5	96.4	8	-8.2
1	HSS6x6x3/8	21	5	8	39.5	5	-104.9
2	HSS6x6x3/8	21	5	5	113.5	8	-35.9
1	HSS6x6x3/8	14.9	4	8	58.5	5	-103.1
2	HSS6x6x3/8	14.9	4	5	115.4	8	-54.7
1	HSS6x6x3/8	14.9	3	8	76.2	5	-117.6
2	HSS6x6x3/8	14.9	3	5	126.8	8	-72.4
1	HSS6x6x3/8	14.9	2	8	94.3	5	-103.1
2	HSS6x6x3/8	14.9	2	5	112.5	8	-90.4
					Max Comp	Max Ten	-117.6
	for HSS6x6x3/8	@ 15'	ØPn =		206.0	ØPn =	-248.0
	for HSS6x6x3/8	@ 21'	ØPn =		138.0	ØPn =	-248.0

Braced Frame - Pinned Bases								
Frame 9/10								
Column	Member	Length	Story	LC	Max P (k)	Max M (k-ft)	Max V (k)	Peff
Column	W14x120	13.33	7	2	28.9	0.1	0	29
				5	26.5	6.4	0.5	37
Column	W14x120	13.33	7	2	84.1	0.2	0	84
				5	75.5	6.5	0.5	87
Column	W14x120	13.33	6	2	126.5	0.7	0.1	128
				5	74.8	6.4	0.4	86
Column	W14x120	13.33	6	5	186.7	6.5	0.2	198
Column	W14x120	20	5	2	216.2	1	0.1	218
				5	95	10.6	0.7	113
Column	W14x120	20	5	5	318.4	9.8	0.7	335
Column	W14x120	13.33	4	2	351.3	2.5	0.3	356
				5	69.7	10.6	1.5	88
Column	W14x120	13.33	4	5	586.2	9.8	1.1	603
Column	W14x120	13.33	3	2	458.8	12.6	1.1	480
				5	57.7	35.4	3.4	118
Column	W14x120	13.33	3	5	780.9	16.4	1.6	809
Column	W14x120	13.33	2	2	529.2	49.4	5	614
				5	5	36.2	5.7	67
Column	W14x120	13.33	2	5	982.3	39.7	1.9	1050
				6	875.9	55.3	4.3	971
Column	W14x120	12.5	1	2	624	47.5	4.1	705
				9	-438	76.9	6.6	-306
Column	W14x120	12.5	1	5	1236.1	119.7	10.3	1441
					Max P	Max M	Max V	Max Peff
					1236.1	119.7	10.3	1441
W14x120	@ 13.3'	∅Xn			1390.0	795.0		1390.0
W14x120	@12.5	∅Xn			1415		+/-5%	1415
W14x132	@12.5	∅Xn			1555			1555

Beam	Member	Length	Story	LC	Max M (k-ft)	Max V (k)
Beam	W16x31	17.9	8	2	5.2	44.4
Beam	W18x35	17.9	7	2	8.9	65.5
Beam	W18x35	17.9	6	2	25.2	67.3
Beam	W18x35	17.9	5	2	27.7	108
Beam	W18x35	17.9	4	2	27.6	67.7
Beam	W18x35	17.9	3	2	35.8	68.6
Beam	W21x68	17.9	2	5	166.3	36.8
					Max M	Max V
					166.3	108.0
W18x35	∅Mr				249.0	159.0
W21x68	∅Mr				600.0	273

Brace	Member	Length	Story	LC	(Comp) Max P+ (k)	LC	(Tens) Max P (k)
1	HSS6x6x3/8	16	7	2	77.1	9	-20.1
2	HSS6x6x3/8	16	7	9	49.6	2	-22.8
1	HSS6x6x3/8	16	6	2	90.2	9	-50.2
2	HSS6x6x3/8	16	6	9	80	2	-2.4
1	HSS8x6x1/2	22	5	2	99.1	9	-143.5
2	HSS8x6x1/2	22	5	9	172.2	2	-14.9
1	HSS6x6x3/8	16	4	2	106.1	9	-123.6
2	HSS6x6x3/8	16	4	9	154.8	-	-
1	HSS6x6x3/8	16	3	2	71.3	9	-147.1
2	HSS6x6x3/8	16	3	9	178.5	-	-
1	HSS6x6x1/2	16	2	2	64.5	9	-171
2	HSS6x6x1/2	16	2	5	203.3	-	-
					Max Comp	Max Ten	-171.0
	for HSS6x6x3/8	@16'	∅Pn =		195	∅Pn =	-248
	for HSS6x6x1/2	@16'	∅Pn =		244	∅Pn =	-318
	for HSS8x6x1/2	@22'	∅Pn =		201	∅Pn =	-378

**APPENDIX G**

Story Displacements for Final Braced Frame Design (as calculated by RAM Structural System)



RAM Frame v11.2  
 DataBase: Braced Frame - Pinned Bases -  
 Building Code: IBC

**Story Displacements**

**CRITERIA:**

Rigid End Zones: Ignore Effects  
 Member Force Output: At Face of Joint  
 P-Delta: No  
 Ground Level: Base  
 Wall Mesh Criteria :  
     Wall Element Type : Shell Element with No Out-of-Plane Stiffness  
     Max. Allowed Distance between Nodes (ft) : 8.00

**LOAD CASE DEFINITIONS:**

D	DeadLoad	RAMUSER
Lp	PosLiveLoad	RAMUSER
E1	Seismic E-W	EQ_User
E2	Seismic N-S	EQ_User
W1	Wind E-W	W_User
W2	Wind N-S	W_User

**LOAD COMBINATIONS: User Specified**

11	*	1.0D + 1.0W1 + 1.0Lp
12	*	1.0D + 1.0W2 + 1.0Lp
13	*	1.0D + 1.0E1 + 1.0Lp
14	*	1.0D + 1.0E2 + 1.0Lp
15	*	1.0D + 1.0W1
16	*	1.0D + 1.0W2
17	*	1.0D + 1.0E1 + .3E2
18	*	1.0D + 1.0E2 + .3E1

\* = Load combination currently selected to use

**Level: 8th future roof, Diaph: 1**

Center of Mass (ft): (-16.35, 94.19)

LdC	Disp X in	Disp Y in	Theta Z rad
11	1.45133	0.03323	0.00004
12	0.04982	2.16015	0.00007
13	4.66293	0.10974	0.00003
14	0.10957	4.73251	0.00016
15	1.45164	0.03289	0.00001
16	0.05013	2.15981	0.00004
17	4.69603	1.52909	0.00003
18	1.50867	4.76503	0.00012

**Level: 7th future, Diaph: 1**

Center of Mass (ft): (-16.28, 94.17)

LdC	Disp X	Disp Y	Theta Z
-----	--------	--------	---------



RAM Frame v11.2  
 DataBase: Braced Frame - Pinned Bases -  
 Building Code: IBC

### Story Displacements

	in	in	rad
11	1.28476	0.02863	0.00003
12	0.04300	1.91519	0.00005
13	4.02553	0.08991	0.00002
14	0.09010	4.09889	0.00014
15	1.28513	0.02835	0.00000
16	0.04337	1.91490	0.00003
17	4.05294	1.31923	0.00002
18	1.29814	4.12552	0.00010

#### Level: 6th future, Diaph: 1

Center of Mass (ft): (-16.28, 94.17)

LdC	Disp X in	Disp Y in	Theta Z rad
11	1.09806	0.02330	0.00002
12	0.03580	1.63596	0.00004
13	3.32770	0.06826	0.00000
14	0.06940	3.39355	0.00011
15	1.09807	0.02307	-0.00000
16	0.03581	1.63573	0.00002
17	3.34840	1.08604	0.00000
18	1.06759	3.41374	0.00008

#### Level: 5th Floor, Diaph: 1

Center of Mass (ft): (-16.28, 94.17)

LdC	Disp X in	Disp Y in	Theta Z rad
11	0.77669	0.02293	-0.00001
12	0.03430	1.12325	0.00002
13	2.19976	0.06743	-0.00003
14	0.06669	2.17443	0.00006
15	0.77682	0.02285	-0.00002
16	0.03443	1.12317	0.00001
17	2.21989	0.71968	-0.00003
18	0.72674	2.19457	0.00004

#### Level: 4rd Floor, Diaph: 1

Center of Mass (ft): (-16.30, 94.17)

LdC	Disp X in	Disp Y in	Theta Z rad
11	0.57189	0.01507	-0.00002
12	0.02283	0.79545	0.00001
13	1.52912	0.04216	-0.00005
14	0.04164	1.45170	0.00004
15	0.57184	0.01502	-0.00002



**Story Displacements**

RAM Frame v11.2  
 DataBase: Braced Frame - Pinned Bases -  
 Building Code: IBC

---

16	0.02278	0.79540	0.00000
17	1.54150	0.47762	-0.00004
18	0.50026	1.46430	0.00002

**Level: 3rd Floor, Diaph: 1**

Center of Mass (ft): (-16.30, 94.17)

LdC	Disp X in	Disp Y in	Theta Z rad
11	0.35858	0.00524	-0.00002
12	0.00828	0.47869	0.00000
13	0.88857	0.01308	-0.00005
14	0.01284	0.80988	0.00002
15	0.35857	0.00522	-0.00003
16	0.00827	0.47867	0.00000
17	0.89239	0.25602	-0.00005
18	0.27938	0.81378	0.00000

**Level: 2nd Floor, Diaph: 1**

Center of Mass (ft): (-16.26, 94.17)

LdC	Disp X in	Disp Y in	Theta Z rad
11	0.18977	0.00131	-0.00003
12	0.00213	0.21059	-0.00000
13	0.43024	0.00253	-0.00006
14	0.00186	0.32144	0.00001
15	0.18980	0.00131	-0.00003
16	0.00216	0.21059	-0.00000
17	0.43084	0.09896	-0.00006
18	0.13097	0.32220	-0.00001

**APPENDIX H**

Structural details of lateral column base plate connection

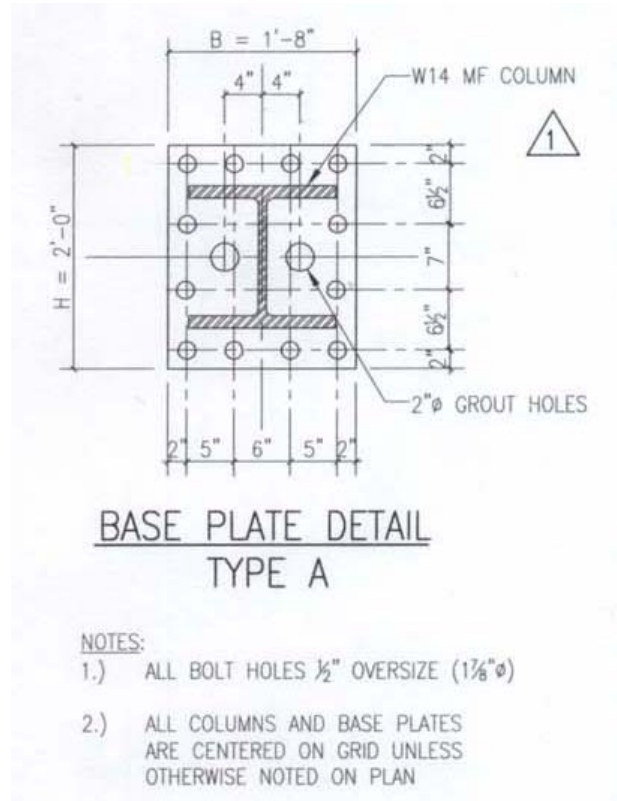

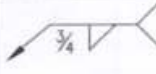
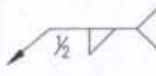
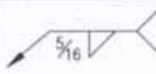
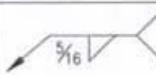
TYPE	ANCHOR ROD		ROD MATERIAL	NUT MATERIAL	WELD	GROUT	NOTES
	DIAMETER	L					
A	1 1/4" $\phi$	2'-0"	*	A563 GRADE A		1 1/2" MIN.	-
B	1 1/4" $\phi$	2'-0"	*	A563 GRADE A		1 1/2" MIN.	-
C	1 1/4" $\phi$	1'-0"	*	A563 GRADE A		1 1/2" MIN.	-
D	1 1/4" $\phi$	1'-0"	*	A563 GRADE A		1 1/2" MIN.	-

**APPENDIX I**

Braced Frame - Fixed Bases								
Frame 1/8								
Column	Member	Length	Story	LC	Max P (k)	Max M (k-ft)	Max V (k)	Peff (k)
Column	W14x120	13.33	7	2	49.1	0.3	0.0	50
				6	44.1	2.5	0.2	48
Column	W14x120	13.33	7	2	20.3	0.3	0.0	21
				6	18.3	2.5	0.2	23
Column	W14x120	13.33	6	6	94.5	40.6	2.9	164
Column	W14x120	13.33	6	5	117.7	40.5	2.9	187
Column	W14x120	20	5	6	195.0	43.5	4.2	270
Column	W14x120	20	5	5	217.3	43.5	4.2	292
Column	W14x120	13.33	4	5	302.7	43.5	3.8	377
Column	W14x120	13.33	4	5	35.6	43.5	3.8	110
				6	229.2	40.0	3.0	298
Column	W14x176	13.33	3	5	433.3	15.5	1.7	460
Column	W14x176	13.33	3	5	-22.5	16.4	1.8	6
				6	355.5	7.0	0.6	368
Column	W14x176	13.33	2	5	570.5	35.7	1.7	632
				6	8.2	41.2	2.7	79
Column	W14x176	13.33	2	6	472.8	44.6	3.1	549
Column	W14x176	12.5	1	5	754.3	374.5	52.0	1396
Column	W14x176	12.5	1	4	555.5	377.7	53.6	1203
				6	634.6	353.9	49.6	1241
					Max P	Max M	Max V	Max Peff
					754.3	377.7	53.6	1396
W14x120	@ 13.3'	∅Xn			1390.0	795.0		1390.0
W14x176	@ 12.5'	∅Xn			2105			2105

Beam	Member	Length	Story	LC	Max M (k-ft)	Max V (k)
Beam	W10x12	13.25	8	2	1.9	1.6
Beam	W10x12	13.25	7	2	3.4	2.6
Beam	W10x12	13.25	6	2	-	4.1
Beam	W10x12	13.25	5	2	6.3	33.0
Beam	W10x12	13.25	4	2	4.4	2.7
Beam	W10x12	13.25	3	2	4.7	2.8
Beam	W27x146	13.25	2	4	303.0	53.0
					Max M	Max V
					303.0	53.0
W10x12	∅Mr				46.9	56.0
W27x146	∅Mr				1740.0	497.0

Brace	Member	Length	Story	LC	(Comp) Max P+ (k)	LC	(Ten) Max P- (k)
1	HSS6x6x3/8	14.9	7	6	58.7	9	-20.6
2	HSS6x6x3/8	14.9	7	9	22.1	6	-56.1
1	HSS6x6x3/8	14.9	6	6	90.0	5	-49.4
2	HSS6x6x3/8	14.9	6	5	53.2	6	-86.2
1	HSS6x6x3/8	14.9	4	6	120.8	5	-84.6
2	HSS6x6x3/8	14.9	4	5	90.5	6	-114.9
1	HSS6x6x3/8	14.9	3	6	111.2	5	-95.2
2	HSS6x6x3/8	14.9	3	5	99.2	6	-107.2
1	HSS6x6x3/8	14.9	2	6	105.5	5	-93.7
2	HSS6x6x3/8	14.9	2	5	97.8	4	-101.3
					Max Comp	Max Ten	
					120.8	-114.9	
					∅Pn = 206.0	∅Pn =	-248.0

Braced Frame - Fixed Bases								
Frame 2/7								
Column	Member	Length	Story	LC	Max P (k)	Max M (k-ft)	Max V (k)	Peff (k)
Column	W14x120	13.33	7	2	28.8	0.1	0	29
				5	26.4	2.6	0.2	31
Column	W14x120	13.33	7	2	46.5	0.1	0	47
				5	41.7	2.6	0.2	46
Column	W14x120	13.33	6	2	97.6	0.4	0	98
				5	72.4	58	4.1	172
Column	W14x120	13.33	6	5	114	57.8	4.1	213
Column	W14x120	20	5	2	166.2	0.4	0	167
				5	67.4	65	6.1	179
Column	W14x120	20	5	5	231.8	64.6	6.1	343
Column	W14x120	13.33	4	2	268.2	1	0.1	270
				5	-171	65	6.1	-60
Column	W14x120	13.33	4	5	640.2	64.5	5.8	751
Column	W14x176	13.33	3	2	354.9	7.4	0.6	368
				5	-251.8	27.8	3.3	-204
Column	W14x176	13.33	3	5	861.5	16.3	2.2	889
				9	703.6	19.3	2.6	737
Column	W14x176	13.33	2	2	410.8	29	3	461
Column	W14x176	13.33	2	5	1044.3	52.5	3	1134
Column	W14x176	12.5	1	2	491.3	32.2	4.2	547
				9	-698	480	65.9	125
Column	W14x176	12.5	1	5	1356	493.7	69	2202
					Max P	Max M	Max V	Max Peff
					1356.0	493.7	69.0	2202
W14x120	@ 13.3'	ØXn			1390.0	795.0		1390
W14x145	@ 12.5'	ØXn			1730			1730
W14x176	@ 12.5'	ØXn			2105		+/-5%	2105
W14x193	@ 12.5'	ØXn			2310			2310

Beam	Member	Length	Story	LC	Max M (k-ft)	Max V (k)
Beam	W16x26	18	8	2	2.34	39.6
Beam	W16x31	18	7	2	5.9	60.1
Beam	W16x31	18	6	2	13.5	60.9
Beam	W18x35	18	5	2	18.6	97.1
Beam	W16x31	18	4	2	11.8	60.7
Beam	W16x31	18	3	2	17.1	61.3
Beam	W27x146	18	2	5	401.6	97.1
					Max M	Max V
					401.6	97.1
W16x31	ØMr				203.0	131
W27x146	ØMr				1740.0	497

Brace	Member	Length	Story	LC	(Comp) Max P+ (k)	LC	(Ten) Max P- (k)
1	HSS6x6x3/8	16	7	2	39.2	-	-
2	HSS6x6x3/8	16	7	5	25.1	-	-
1	HSS6x6x3/8	16	6	2	56.9	9	-60.6
2	HSS6x6x3/8	16	6	5	95.1	-	-
1	HSS12x6x5/8	22	5	2	56.7	9	-333.5
2	HSS12x6x5/8	22	5	5	363.9	-	-
1	HSS8x6x1/2	16	4	2	75.5	9	-164.3
2	HSS8x6x1/2	16	4	5	214.3	-	-
1	HSS6x6x3/8	16	3	2	47.4	9	-138
2	HSS6x6x3/8	16	3	5	177.3	-	-
1	HSS8x6x1/2	16	2	2	46.7	9	-218.3
2	HSS8x6x1/2	16	2	5	258.2	-	-
					Max Comp	Max Ten	-333.5
	for HSS6x6x3/8			ØPn =	195	ØPn =	-248
	for HSS8x6x1/2			ØPn =	303	ØPn =	-378
	for HSS12x6x5/8			ØPn =	340.0	ØPn =	-609.0



Braced Frame - Fixed Bases								
Frame 3/6								
Column	Member	Length	Story	LC	Max P (k)	Max M (k-ft)	Max V (k)	Peff (k)
Column	W14x120	13.33	7	2	39.5	0.1	0	40
				10	22.4	4.7	0.3	30
Column	W14x120	13.33	7	2	51.8	0.1	0	52
				10	28.2	4.7	0.3	36
Column	W14x120	13.33	6	2	112.6	2.8	0.2	117
				10	30.4	55	3.8	125
Column	W14x120	13.33	6	6	122.8	56.4	3.9	219
Column	W14x120	20	5	2	177.3	2.9	0.3	182
				6	63.8	57.6	5.7	163
Column	W14x120	20	5	6	241.3	57.3	5.7	340
Column	W14x120	13.33	4	2	281.4	2.8	0.4	286
				6	-175	57.6	4.7	-76
Column	W14x120	13.33	4	6	65.8	57.3	4.6	164
Column	W14x193	13.33	3	2	351.6	3.9	0.4	358
				6	-245	22.4	2.1	-207
Column	W14x193	13.33	3	6	843.4	18.5	1.8	875
Column	W14x193	13.33	2	2	407.9	16.2	1.6	436
				10	-508	26	0.4	-463
Column	W14x193	13.33	2	6	1037	45.7	2.4	1115
Column	W14x193	12.5	1	2	474.1	17.1	2.3	503
				4	-301	584	80.8	700
Column	W14x193	12.5	1	4	1124.7	597.5	84.3	2149
				6	1328.5	560.5	78	2289
					Max P	Max M	Max V	Max Peff
					1328.5	597.5	84.3	2289
	W14x120	@ 13.3'	ØXn		1390.0	795.0		1390
	W14x176	@ 12.5'	ØXn		2105			2105
	W14x193	@ 12.5'	ØXn		2310			2310

Beam	Member	Length	Story	LC	Max M (k-ft)	Max V (k)
Beam	W12x19	18	8	2	15.3	8.8
Beam	W12x19	18	7	2	25.6	14.4
Beam	W12x19	18	6	2	28.3	14.7
Beam	W12x19	18	5	2	40.2	21.8
Beam	W12x19	18	4	2	27.6	14.6
Beam	W12x19	18	3	2	28.6	14.7
Beam	W27x146	18	2	4	460.3	69.9
					Max M	Max V
					460.3	69.9
	W12x19	ØMr			92.6	85.7
	W27x146	ØMr			1740.0	497

Brace	Member	Length	Story	LC	(Comp) Max P+ (k)	LC	(Ten) Max P- (k)
1	HSS8x6x3/8	16	7	2	26.2	10	-17.3
2	HSS8x6x3/8	16	7	10	28.6	2	-5
1	HSS8x6x3/8	16	6	2	31.4	10	-72.7
2	HSS8x6x3/8	16	6	10	84.1	-	-
1	HSS12x6x5/8	22	5	2	22.9	10	-343.2
2	HSS12x6x5/8	22	5	6	357.2	-	-
1	HSS8x6x3/8	16	4	2	37.1	10	-146.6
2	HSS8x6x3/8	16	4	6	166.5	-	-
1	HSS8x6x3/8	16	3	2	25	10	-164.6
2	HSS8x6x3/8	16	3	6	178.1	-	-
1	HSS8x6x3/8	16	2	2	22.8	10	-213.1
2	HSS8x6x3/8	16	2	6	227.6	-	-
					Max Comp	Max Ten	-343.2
	HSS8x6x3/8	@ 16'	ØPn =		239.0	ØPn =	-293.0
	HSS12x6x5/8	@ 22'	ØPn =		340.0	ØPn =	-457.0

Braced Frame - Fixed Bases								
Frame 4/5								
Column	Member	Length	Story	LC	Max P (k)	Max M (k-ft)	Max V (k)	Peff (k)
Column	W14x120	13.33	7	2	11.5	0.3	0	12
				6	10.5	2.5	0.2	15
Column	W14x120	13.33	7	2	65.83	0.3	0	66
				6	59	2.5	0.2	63
Column	W14x120	13.33	6	5	104.8	40	2.9	173
Column	W14x120	13.33	6	6	126.7	40.5	2.8	196
Column	W14x120	20	5	5	226.5	43.2	4.2	301
Column	W14x120	20	5	5	31	43.5	4.2	106
				6	224.6	40.4	4	294
Column	W14x120	13.33	4	5	245	43.2	3.7	319
Column	W14x120	13.33	4	5	146.6	43.5	3.8	221
				6	340.2	39.7	3	408
Column	W14x176	13.33	3	5	375	12.3	1.4	396
Column	W14x176	13.33	3	5	102.4	14.1	1.6	127
				6	479.8	9.3	0.8	496
Column	W14x176	13.33	2	5	501.5	48.5	3	585
Column	W14x176	13.33	2	5	56	41.6	2.2	127
				6	618.1	35.4	2.1	679
Column	W14x176	12.5	1	5	669.8	381.3	53.8	1323
Column	W14x176	12.5	1	6	808.8	349	48.2	1407
					Max P	Max M	Max V	Max Peff
					808.8	381.3	53.8	1407
W14x120	@ 13.3'			ØXn	1390.0	795.0		1390
W14x176	@ 12.5'			ØXn	2105			2105

Beam	Member	Length	Story	LC	Max M (k-ft)	Max V (k)
Beam	W10x12	13.25	8	2	4	3.2
Beam	W10x12	13.25	7	2	6.9	5.3
Beam	W10x12	13.25	6	2	-	8.6
Beam	W10x12	13.25	5	2	11.3	8.1
Beam	W10x12	13.25	4	2	8	5.5
Beam	W10x12	13.25	3	2	8.4	5.7
Beam	W27x146	13.25	2	5	309.9	58
					Max M	Max V
					309.9	58.0
W10x12				ØMr	46.9	56.0
W27x146				ØMr	1740.0	497

Brace	Member	Length	Story	LC	(Comp) Max P+ (k)	LC	(Ten) Max P (k)
1	HSS6x6x3/8	14.9	7	10	5	5	-83.6
2	HSS6x6x3/8	14.9	7	5	89.6	10	-1.5
1	HSS6x6x3/8	14.9	6	10	29.5	5	-109.8
2	HSS6x6x3/8	14.9	6	5	118.5	10	-25.9
1	HSS6x6x3/8	14.9	4	6	81.8	5	-123.6
2	HSS6x6x3/8	14.9	4	5	135.9	6	-69.4
1	HSS6x6x3/8	14.9	3	6	83	5	-123.3
2	HSS6x6x3/8	14.9	3	5	132.3	8	-74.9
1	HSS6x6x3/8	14.9	2	8	91.5	5	-107.6
2	HSS6x6x3/8	14.9	2	5	116.7	8	-87.7
					Max Comp	Max Ten	
					135.9	-123.6	
					ØPn =	ØPn =	
					206.0	-248.0	

Braced Frame - Fixed Bases								
Frame 9/10								
Column	Member	Length	Story	LC	Max P (k)	Max M (k-ft)	Max V (k)	Peff (k)
Column	W14x120	13.33	7	2	28.9	0.2	0	29
				6	26.5	4	0.3	33
Column	W14x120	13.33	7	2	84.1	0.2	0	84
				6	75.5	4	0.3	82
Column	W14x120	13.33	6	2	129.8	1.5	0.1	132
				10	-1	50.8	3.5	86
Column	W14x120	13.33	6	5	202	39.7	2.8	270
				9	154.4	52.1	3.6	244
Column	W14x120	20	5	2	253.4	1.4	0.1	256
				9	-60	59.4	5.6	42
Column	W14x120	20	5	5	383.7	46.1	4.3	463
				9	323	59.2	5.6	424
Column	W14x120	13.33	4	2	313.7	1.2	0	316
				9	-44	59.4	4.9	58
Column	W14x120	13.33	4	5	530.3	46.1	4.4	609
				9	368.3	59.2	5.6	470
Column	W14x176	13.33	3	2	425.3	10.1	0.8	443
				5	81.1	30	3.4	133
Column	W14x176	13.33	3	5	759.6	16.2	2.2	787
Column	W14x176	13.33	2	2	497.1	39.2	4	564
Column	W14x176	13.33	2	5	971.2	45	2.3	1048
Column	W14x176	12.5	1	2	593.6	43.9	5.7	669
				10	-488	580	80.8	506
Column	W14x176	12.5	1	5	1272.2	475	67.7	2086
				9	1113.6	605.8	85	2152
					Max P	Max M	Max V	Max Peff
					1272.2	605.8	85.0	2152
W14x120	@ 13.3'	ØXn			1390.0	795.0		1390
W14x176	@ 12.5'	ØXn			2105		+/-5%	2105

Beam	Member	Length	Story	LC	Max M (k-ft)	Max V (k)
Beam	W16x31	17.9	8	2	5.2	44.4
Beam	W18x35	17.9	7	2	8.9	65.5
Beam	W18x35	17.9	6	2	-	35.8
Beam	W18x35	17.9	5	2	27.7	108
Beam	W18x35	17.9	4	2	19.4	66.8
Beam	W18x35	17.9	3	2	25.8	67.5
Beam	W27x146	17.9	2	9	465.8	65.5
					Max M	Max V
					465.8	108.0
W18x35	ØMr				249.0	159.0
W27x146	ØMr				1740.0	497

Brace	Member	Length	Story	LC	(Comp) Max P+ (k)	LC	(Ten) Max P- (k)
1	HSS6x6x3/8	16	7	2	81.4	9	-46.3
2	HSS6x6x3/8	16	7	9	75.8	2	-27.1
1	HSS6x6x3/8	16	6	2	95.8	9	-102.3
2	HSS6x6x3/8	16	6	9	132.1	2	-8
1	HSS6x6x1/2	16	4	2	107.9	10	-192.4
2	HSS6x6x1/2	16	4	10	223.5	-	-
1	HSS6x6x3/8	16	3	2	69.6	9	-169.5
2	HSS6x6x3/8	16	3	9	200.2	-	-
1	HSS6x6x1/2	16	2	2	62.3	9	-205
2	HSS6x6x1/2	16	2	10	236.1	-	-
					Max Comp	Max Ten	-205.0
	for HSS6x6x3/8			ØPn =	195.0	ØPn =	-248.0
	for HSS6x6x1/2			ØPn =	244.0	ØPn =	-318.0

## APPENDIX J

Member sizes of Frame 1 and Frame 4, respectively. (Also frames 5 and 8 due to symmetry)

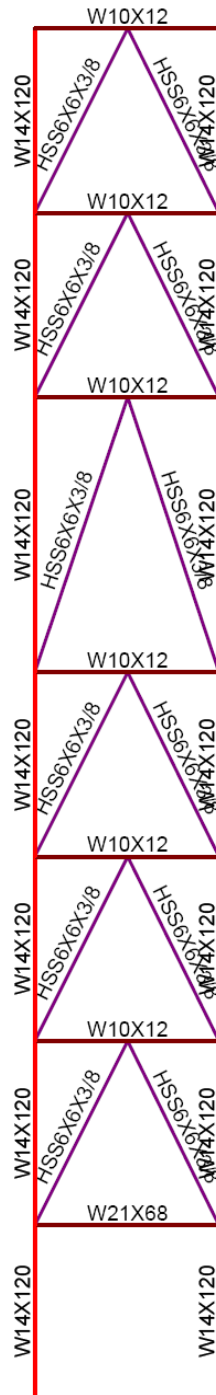

**FRAME 1**

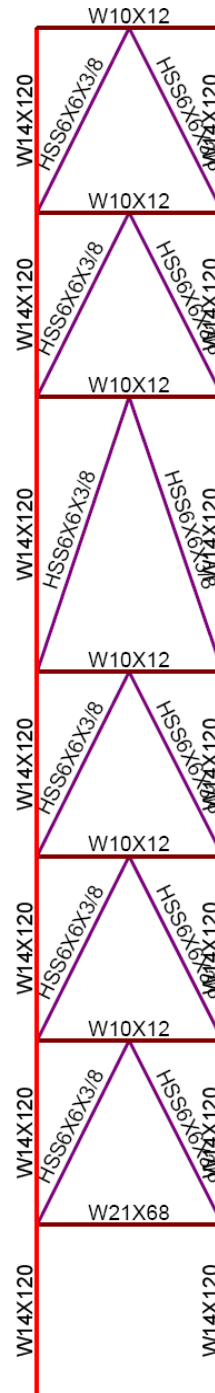

**FRAME 4**

Member sizes of Frame 2 and Frame 3, respectively. (Also frames 6 and 7 due to symmetry)

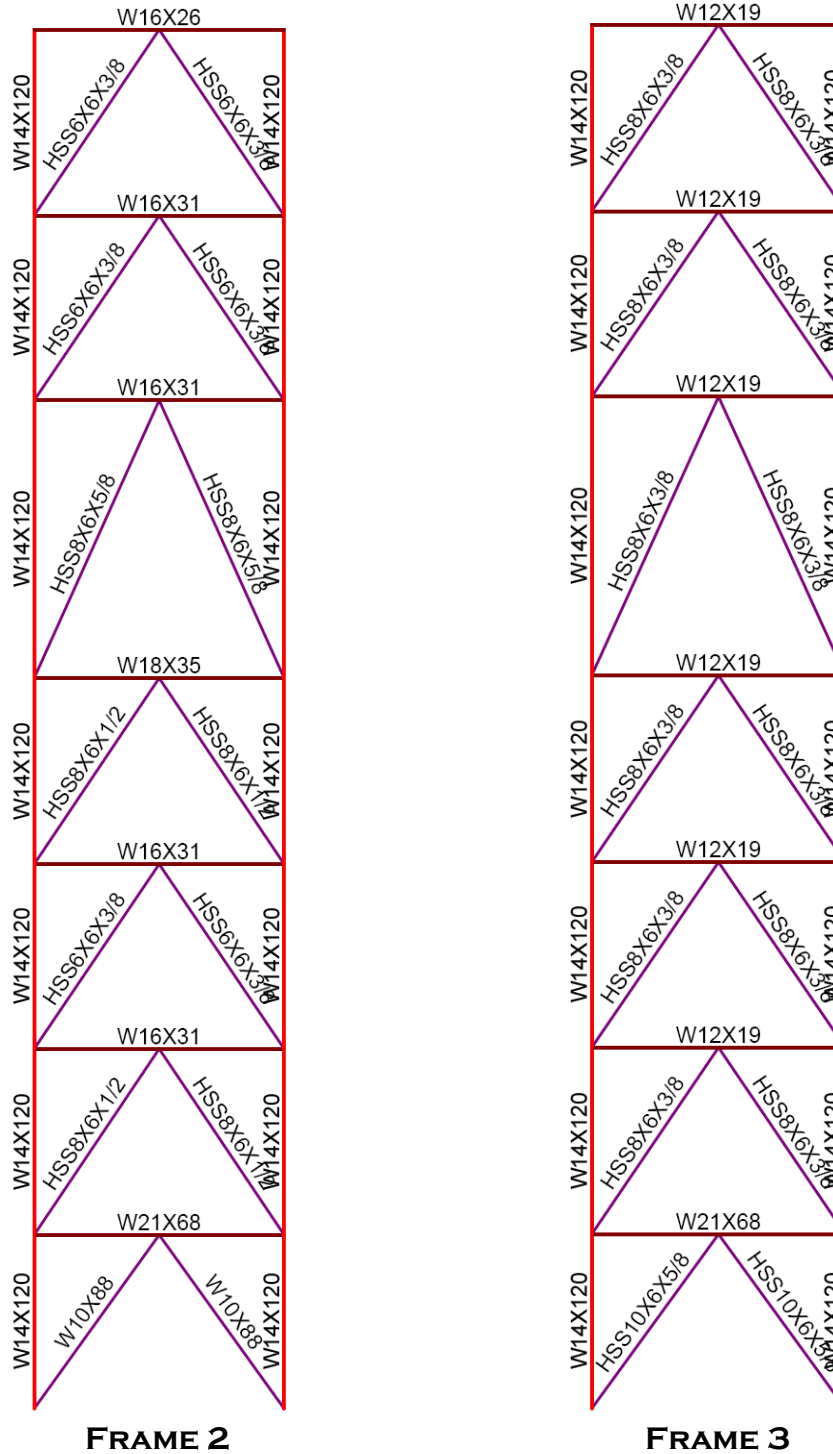

Member sizes of Frame 9. (Also frame 10 due to symmetry)



**FRAME 9**

**APPENDIX K**

Existing CPM Construction Schedule for Moment Frame Steel System

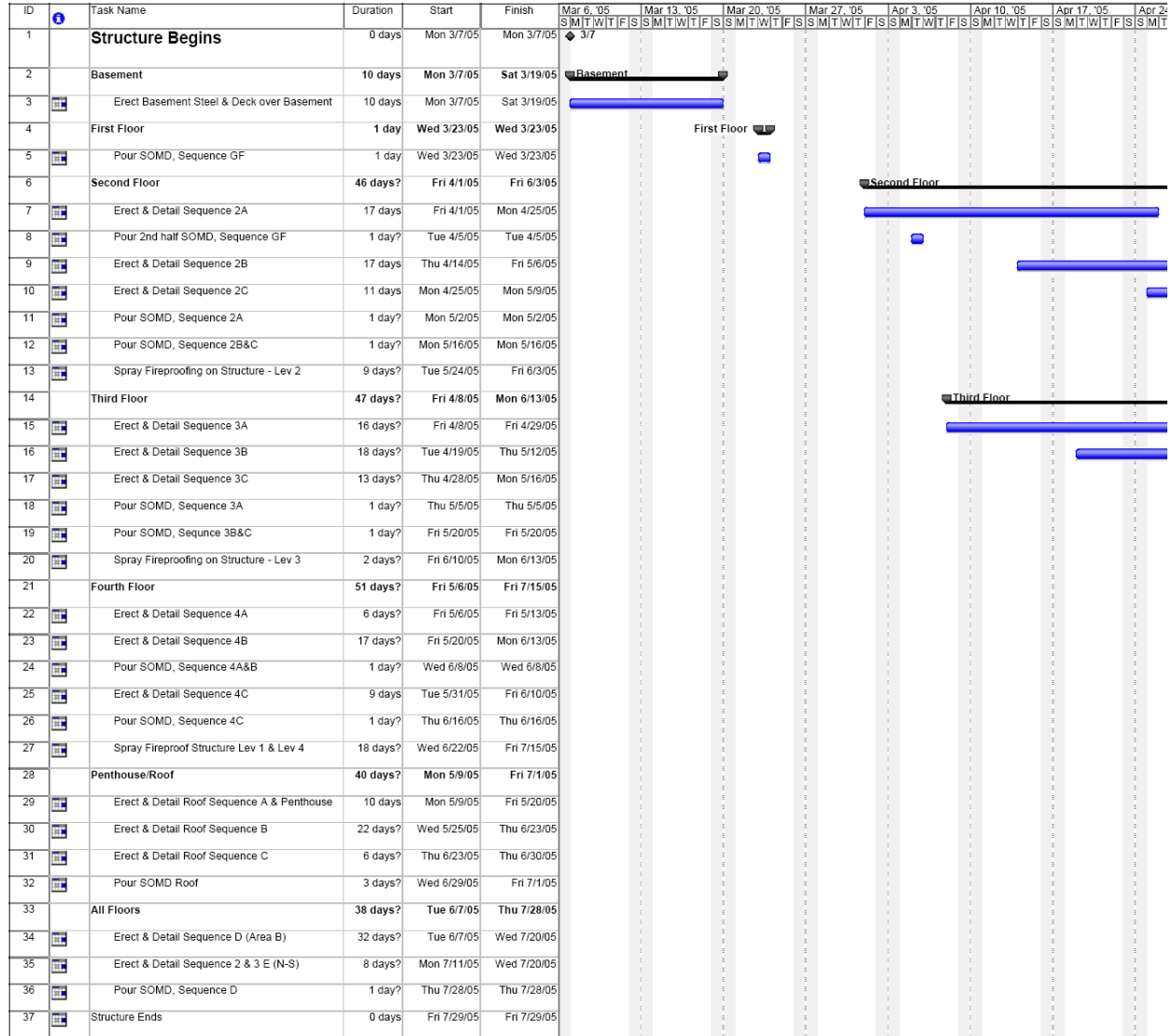

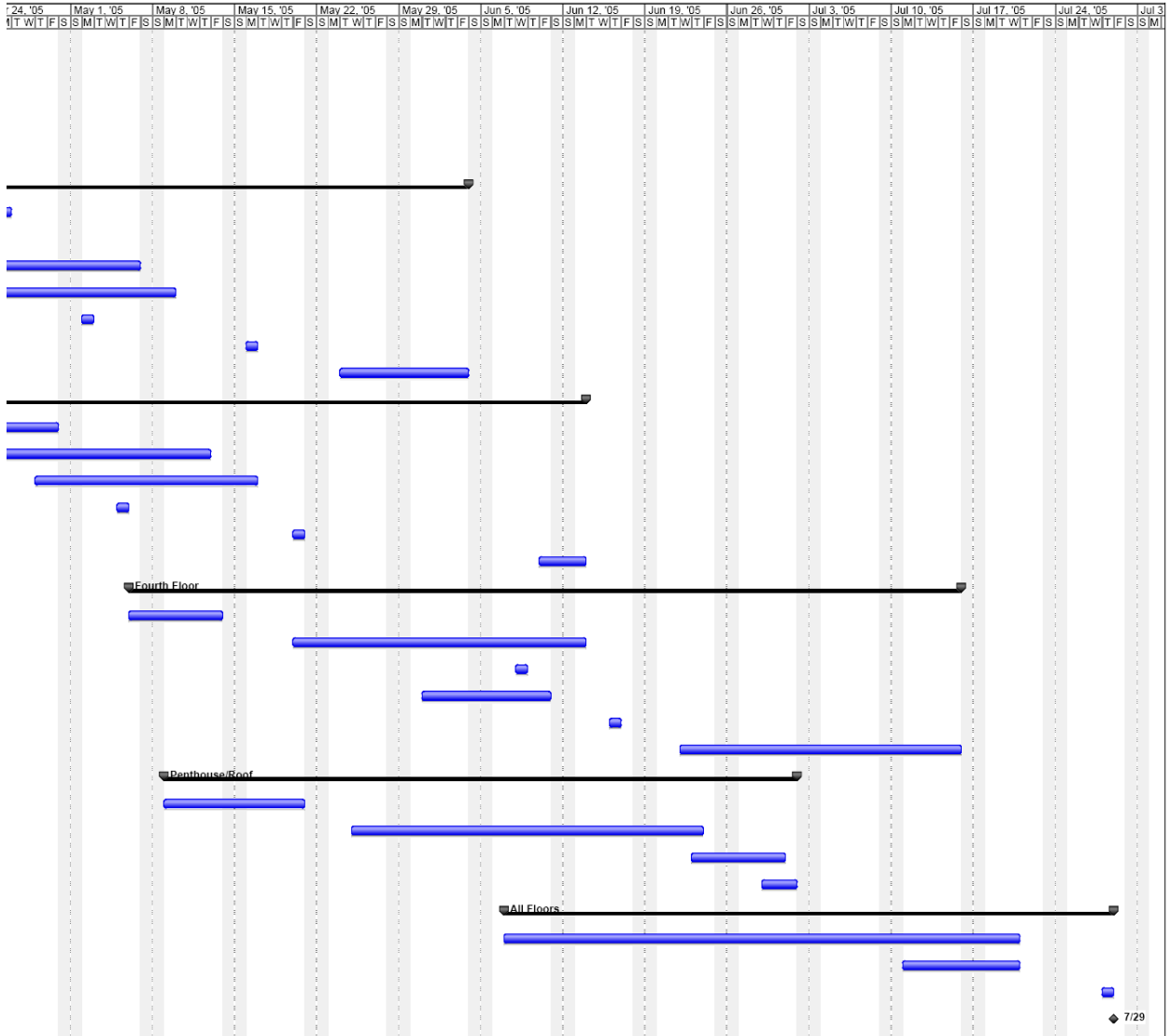



**APPENDIX L**

Proposed CPM Construction Schedule for Braced Frame Steel System.

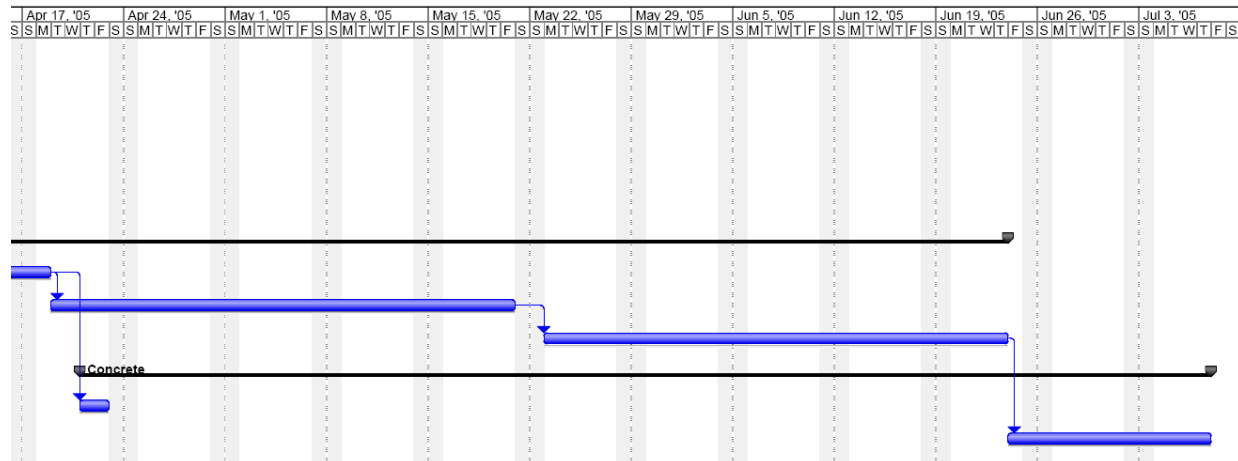
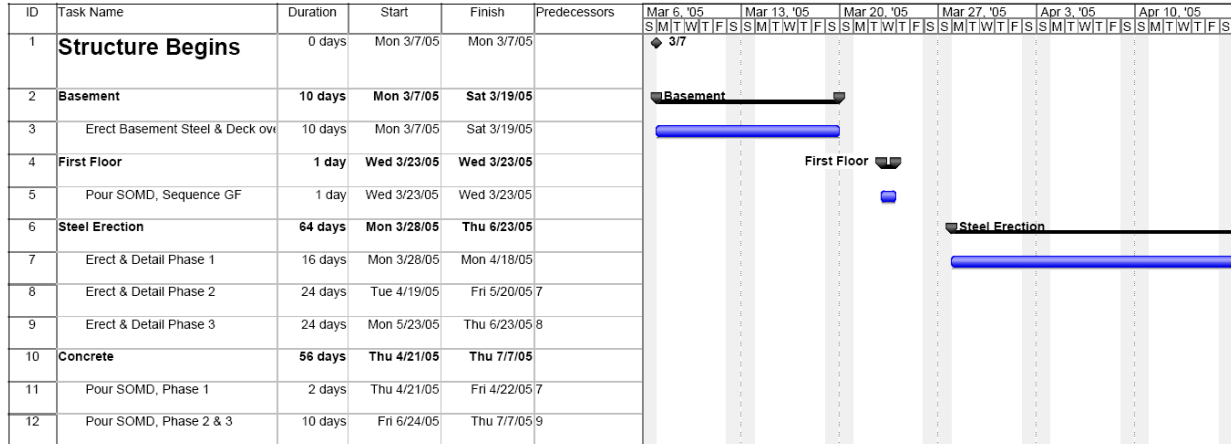

**APPENDIX M**

**HEAVY-LIFT BOOM RANGE DIAGRAM**

**No. 84 Main Boom**

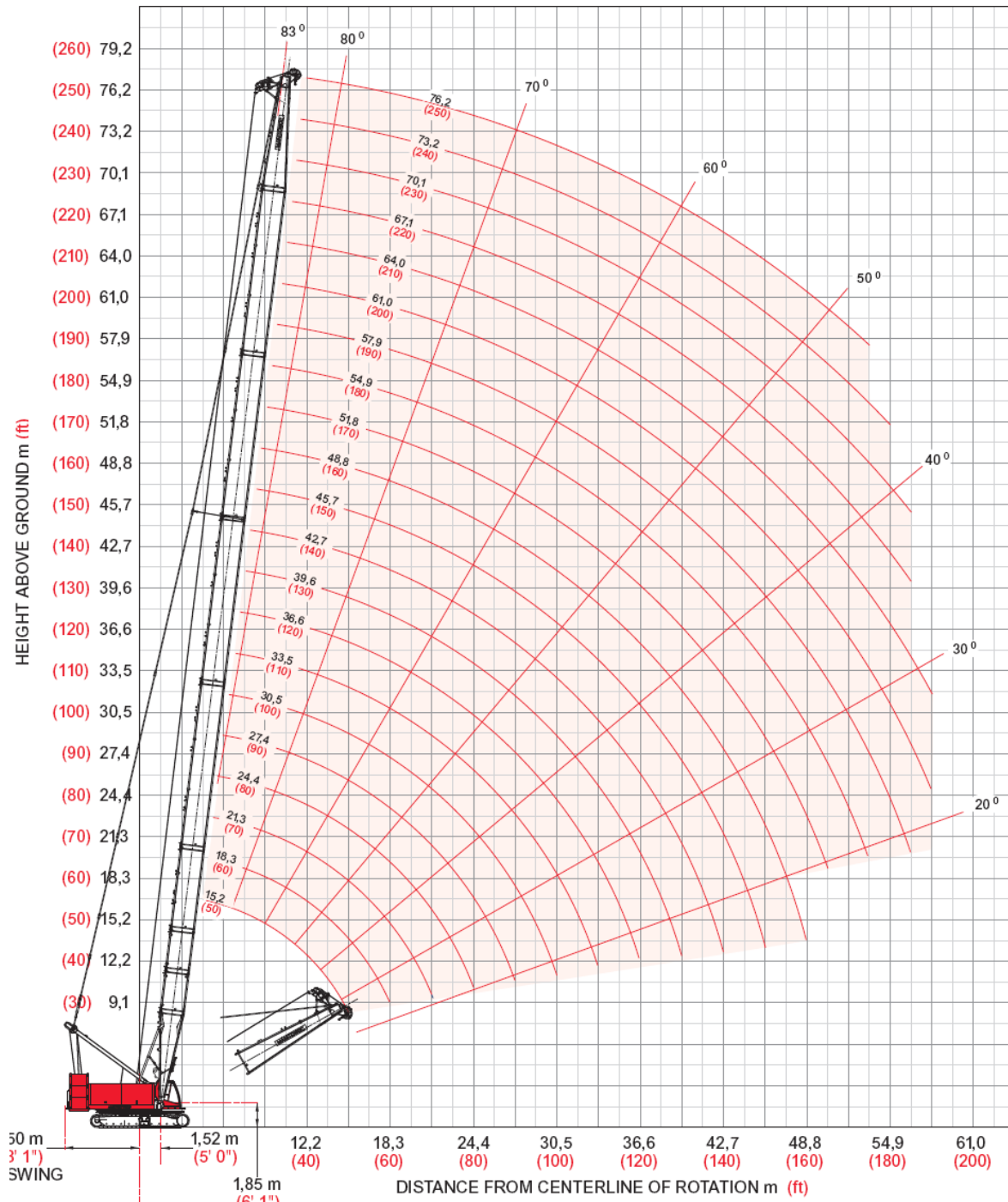

**HEAVY-LIFT LOAD CHARTS**

**Liftcrane Boom Capacities - Series 2  
 Boom No. 84**

**44 678 kg (98,500 lb) Upperworks Counterweight 19 958 kg (44,000 lb) Carbody Counterweight**

**360° Rating kg (lb) x 1 000**

Boom m (ft)	15,2 (50.0)	18,3 (60)	21,3 (70)	27,4 (90)	33,5 (110)	39,6 (130)	45,7 (150)	51,8 (170)	57,9 (190)	64,0 (210)	70,1 (230)	76,2 (250)		
<b>Radius</b>														
4,6 (15)	136,0 (300.0)	135,6 (299.0)												
5,0 (17)	125,0 (266.5)	125,0 (266.4)	123,7 (266.2)											
6,0 (20)	104,9 (228.0)	104,9 (227.9)	104,8 (227.7)	100,3 (220.4)										
7,0 (24)	88,3 (179.9)	88,7 (180.6)	88,6 (180.9)	88,9 (181.1)	84,0 (181.3)	- (159.3)								
8,0 (28)	70,9 (141.9)	71,2 (142.5)	71,3 (142.8)	71,4 (142.9)	71,5 (143.0)	69,6 (142.8)	61,9 (133.6)	- (115.7)						
9,0 (32)	59,4 (116.6)	59,7 (117.1)	59,8 (117.4)	59,8 (117.4)	59,9 (117.5)	60,0 (117.3)	58,9 (116.9)	51,5 (110.3)	- (94.8)					
11,0 (36)	44,5 (98.5)	44,7 (99.0)	44,8 (99.2)	44,8 (99.3)	44,8 (99.3)	44,7 (99.0)	44,6 (98.7)	44,4 (98.3)	40,8 (90.2)	36,0 (79.5)				
12,0 (40)	39,3 (84.9)	39,6 (85.4)	39,7 (85.6)	39,7 (85.7)	39,6 (85.6)	39,5 (85.3)	39,4 (85.0)	39,2 (84.6)	38,7 (84.2)	34,5 (75.6)	30,3 (66.3)	- (54.3)		
15,0 (50)	28,7 (62.0)	29,0 (62.7)	29,1 (62.9)	29,1 (63.0)	29,1 (62.9)	29,0 (62.6)	28,8 (62.2)	28,6 (61.7)	28,4 (61.3)	28,4 (60.7)	26,6 (58.1)	21,9 (47.9)		
18,0 (60)		22,4 (48.5)	22,6 (48.9)	22,7 (49.0)	22,6 (48.9)	22,5 (48.6)	22,3 (48.2)	22,1 (47.7)	21,8 (47.2)	21,6 (46.6)	21,4 (46.1)	19,0 (41.4)		
20,0 (70)			19,5 (39.2)	19,6 (39.5)	19,6 (39.4)	19,4 (39.0)	19,2 (38.7)	19,0 (38.1)	18,7 (37.7)	18,5 (37.1)	18,2 (36.5)	17,2 (35.4)		
24,0 (80)				15,0 (32.5)	15,0 (32.5)	14,9 (32.2)	14,7 (31.8)	14,4 (31.2)	14,3 (30.8)	14,0 (30.2)	13,7 (29.6)	13,4 (28.9)		
26,0 (90)				13,3 (27.2)	13,4 (27.3)	13,2 (27.0)	13,0 (26.6)	12,8 (26.0)	12,6 (25.5)	12,3 (24.9)	12,0 (24.3)	11,8 (23.7)		
30,0 (100)					10,7 (23.2)	10,6 (22.9)	10,4 (22.5)	10,2 (21.9)	10,0 (21.5)	9,7 (20.8)	9,4 (20.2)	9,1 (19.6)		
32,0 (110)					9,7 (19.8)	9,5 (19.5)	9,4 (19.2)	9,1 (18.7)	8,9 (18.2)	8,6 (17.5)	8,3 (16.9)	8,1 (16.3)		
36,0 (120)						7,8 (16.8)	7,7 (16.5)	7,4 (15.9)	7,2 (15.5)	6,9 (14.8)	6,6 (14.2)	6,3 (13.6)		
38,0 (130)							7,1 (14.4)	6,9 (14.2)	6,7 (13.7)	6,5 (13.2)	6,2 (12.6)	5,9 (12.0)	5,6 (11.3)	
42,0 (140)								5,7 (12.2)	5,5 (11.7)	5,2 (11.2)	5,0 (10.6)	4,7 (10.0)	4,4 (9.4)	
44,0 (150)									5,1 (10.5)	4,9 (10.0)	4,7 (9.6)	4,4 (9.0)	3,9 (7.7)	
48,0 (160)										4,0 (8.6)	3,8 (8.1)	3,5 (7.5)	3,2 (6.9)	3,0 (6.3)
50,0 (170)											3,6 (7.9)	3,4 (7.5)	3,1 (6.8)	2,9 (6.3)
54,0 (180)												2,7 (5.9)	2,4 (5.3)	2,1 (4.6)
56,0 (185)													2,3 (5.1)	2,1 (4.6)